

A.O. SMITH
GAS-FIRED COMMERCIAL
COPPER BOILERS
FOR HYDRONIC HEATING
AND HOT WATER SUPPLY



USER'S INFORMATION MANUAL

GB/GW-200, -300, -400, -500, -650, -750
SERIES 200, 201, 202, 203



LIGHTING INSTRUCTIONS

These models have an automatic hot surface ignition system mounted on the combustion chamber panel inside the front jacket. This hot surface igniter ignites the main burner gas whenever the system control calls for heat.

Before proceeding with operation of the unit, make sure the boiler and system are filled with water and all air is expelled from the boiler, radiator tank(s) and piping.

WARNING: If the information in this manual is not followed exactly, a fire or explosion may result causing property damage, personal injury or loss of life.

- Do not store or use gasoline or other flammable vapors and liquids in the vicinity of this or any other appliance.

WHAT TO DO IF YOU SMELL GAS

- Extinguish any open flame.
- Do not try to light any appliance.
- Do not touch any electrical switch; do not use any phone in your building.
- Immediately call your gas supplier from a neighbor's phone. Follow the gas supplier's instructions.
- If you cannot reach your gas supplier, call the fire department.
- Installation and service must be performed by a qualified installer, service agency or the gas supplier.

⚠ WARNING

THE MAIN MANUAL GAS SHUT-OFF VALVE MUST HAVE BEEN CLOSED FOR AT LEAST FIVE (5) MINUTES BEFORE LIGHTING. This waiting period is an important safety step. Its purpose is to permit gas that might have accumulated in the combustion chamber to clear. **IF YOU DETECT GAS AT THE END OF THE PERIOD DO NOT PROCEED WITH LIGHTING.** RECOGNIZE THAT GAS ODOR, EVEN IF IT SEEMS WEAK, MAY INDICATE PRESENCE OF ACCUMULATED GAS SOMEPLACE IN THE AREA WITH A RISK OF FIRE OR EXPLOSION.

⚠ WARNING

THERE IS A RISK IN USING FUEL BURNING APPLIANCES SUCH AS GAS WATER BOILERS IN ROOMS, GARAGES OR OTHER AREAS WHERE GASOLINE AND OTHER FLAMMABLE LIQUIDS ARE USED OR STORED, OR ENGINE-DRIVEN EQUIPMENT OR VEHICLES ARE STORED, OPERATED OR REPAIRED. FLAMMABLE VAPORS ARE HEAVY AND TRAVEL ALONG THE FLOOR AND MAY BE IGNITED BY THE BOILER'S MAIN BURNER FLAMES CAUSING FIRE OR EXPLOSION. Some local codes permit operation of gas appliances if installed 18 inches or more above the floor. This may reduce the risk if location in such an area cannot be avoided.

INDEX	PAGE
GENERAL	1
LIGHTING INSTRUCTIONS	2 - 3
OPERATING SEQUENCE, IGNITION CONTROL AND DIA-SCAN II INSTRUCTIONS.	4 - 8
MAINTENANCE	8
CONNECTION DIAGRAM	9
WARRANTY.	10

⚠ WARNING

Should overheating occur or the gas supply fail to shut off, do not turn off or disconnect the electrical supply to the pump. Instead, shut off the gas supply at a location external to the appliance.

⚠ WARNING

Do not use this boiler if any part has been under water. Immediately call a qualified service technician to inspect the boiler and to replace any part of the control system and any gas control which has been under water.

A.O. SMITH
WATER PRODUCTS
COMPANY

A DIVISION OF A.O. SMITH CORPORATION
 EL PASO, TX MC BEE, SC RENTON, WA
 STRATFORD, ONTARIO
 VELDHOVEN, THE NETHERLANDS
 www.hotwater.com

PLEASE KEEP THESE INSTRUCTIONS ADJACENT TO BOILER AND
 NOTIFY OWNER TO KEEP FOR FUTURE REFERENCE.

THE UNIT SHOULD NOT BE INSTALLED DIRECTLY ON A CARPETED FLOOR. A FIRE HAZARD MAY RESULT. Instead, the boiler must be installed on the A. O. Smith Combustible Floor Kit Base or concrete blocks extending beyond the full width and depth of the boiler by at least 3 (76.2mm) inches. If the boiler is installed in a carpeted alcove, the entire floor must be covered with concrete blocks, or use the A. O. Smith Combustible Floor Kit Base.

BE PLACED ON OR ADJACENT TO THE BOILER. OPEN CONTAINERS OF FLAMMABLE MATERIAL SHOULD NOT BE STORED OR USED IN THE SAME ROOM WITH THE BOILER.

Light the unit in accordance with the instructions on the lighting and operating label attached to the boiler. These instructions are repeated on the following two pages.

FLAMMABLE ITEMS, PRESSURIZED CONTAINERS OR ANY OTHER POTENTIAL FIRE HAZARDOUS ARTICLES MUST NEVER

Lighting Instructions for the G(B/W) 200 through 500 models

FOR YOUR SAFETY READ BEFORE OPERATING





WARNING : IF YOU DO NOT FOLLOW THESE INSTRUCTIONS EXACTLY, A FIRE OR EXPLOSION MAY RESULT CAUSING PROPERTY DAMAGE, PERSONAL INJURY OR LOSS OF LIFE.



FLAMMABLE

A. THIS APPLIANCE DOES NOT HAVE A PILOT. IT IS EQUIPPED WITH AN IGNITION DEVICE WHICH AUTOMATICALLY LIGHTS THE BURNER. DO NOT TRY TO LIGHT THE BURNER BY HAND.

B. BEFORE LIGHTING: SMELL ALL AROUND THE APPLIANCE AREA FOR GAS. BE SURE TO SMELL NEXT TO THE FLOOR BECAUSE SOME GAS IS HEAVIER THAN AIR AND WILL SETTLE ON THE FLOOR.

WHAT TO DO IF YOU SMELL GAS

- DO NOT TRY TO LIGHT ANY APPLIANCE.
- DO NOT TOUCH ANY ELECTRIC SWITCH; DO NOT USE ANY PHONE IN YOUR BUILDING.
- IMMEDIATELY CALL YOUR GAS SUPPLIER FROM A NEIGHBOR'S PHONE. FOLLOW THE GAS SUPPLIER'S INSTRUCTIONS.
- IF YOU CANNOT REACH YOUR GAS SUPPLIER, CALL THE FIRE DEPARTMENT.

C. USE ONLY YOUR HAND TO PUSH IN OR TURN THE GAS CONTROL KNOB. NEVER USE TOOLS. IF THE KNOB WILL NOT PUSH IN OR TURN BY HAND, DON'T TRY TO REPAIR IT, CALL A QUALIFIED SERVICE TECHNICIAN. FORCE OR ATTEMPTED REPAIR MAY RESULT IN A FIRE OR EXPLOSION.

D. DO NOT USE THIS APPLIANCE IF ANY PART HAS BEEN UNDER WATER. IMMEDIATELY CALL A QUALIFIED SERVICE TECHNICIAN TO INSPECT THE APPLIANCE AND TO REPLACE ANY PART OF THE CONTROL SYSTEM AND ANY GAS CONTROL WHICH HAS BEEN UNDER WATER.

E. DO NOT OPERATE APPLIANCE UNLESS UNIT IS FILLED WITH WATER AND WATER LINES ARE FULLY OPEN.

ROBERTSHAW

TOP KNOB

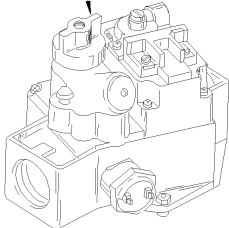



FIGURE "A"



"OFF" POSITION

FIGURE "B"



"ON" POSITION

WHITE - RODGERS

FIGURE "A"

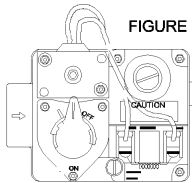

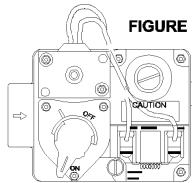

"OFF" POSITION

FIGURE "B"



"ON" POSITION

OPERATING INSTRUCTIONS

1.  **STOP ! READ THE SAFETY INFORMATION ABOVE ON THIS LABEL.**
2. SET THE SYSTEM CONTROLLER TO THE LOWEST SETTING.
3. TURN OFF ALL ELECTRIC POWER TO APPLIANCE.
4. THIS APPLIANCE IS EQUIPPED WITH AN IGNITION DEVICE WHICH AUTOMATICALLY LIGHTS THE BURNER. DO NOT TRY TO LIGHT THE BURNER BY HAND.
5. REMOVE CONTROL ACCESS PANEL.
6. REFER TO DIAGRAMS ABOVE. TURN TOP KNOB OF GAS CONTROL CLOCKWISE  TO "OFF" POSITION, (FIG. A).
7. WAIT FIVE (5) MINUTES TO CLEAR OUT ANY GAS. THEN SMELL FOR GAS, INCLUDING NEAR THE FLOOR. IF YOU SMELL GAS,

8. TURN TOP KNOB OF GAS CONTROL COUNTER-CLOCKWISE  TO "ON" POSITION, (FIG. B).
9. REPLACE CONTROL ACCESS PANEL.
10. TURN POWER SWITCH TO "ON" POSITION (SWITCH LIGHT COMES ON).
11. SET THE SYSTEM CONTROLLER TO DESIRED SETTING.
12. IF THE APPLIANCE WILL NOT OPERATE, FOLLOW THE INSTRUCTIONS "TO TURN OFF GAS TO THE APPLIANCE" AND CALL YOUR SERVICE TECHNICIAN OR GAS SUPPLIER.

TO TURN OFF GAS TO APPLIANCE

1. SET THE SYSTEM CONTROLLER TO THE LOWEST SETTING.
2. TURN POWER SWITCH ON APPLIANCE TO "OFF" POSITION (SWITCH LIGHT GOES OUT).
3. REMOVE ACCESS PANEL TO EXPOSE GAS CONTROL.

4. REFER TO DIAGRAMS ABOVE. TURN TOP KNOB OF GAS CONTROL CLOCKWISE  TO "OFF" POSITION, (FIG. A).
5. REPLACE CONTROL ACCESS PANEL.

Lighting Instructions for the G(B/W) 650 and 750 models

FOR YOUR SAFETY READ BEFORE OPERATING



WARNING: IF YOU DO NOT FOLLOW THESE INSTRUCTIONS EXACTLY, A FIRE OR EXPLOSION MAY RESULT CAUSING PROPERTY DAMAGE, PERSONAL INJURY OR LOSS OF LIFE.



- A. THIS APPLIANCE DOES NOT HAVE A PILOT. IT IS EQUIPPED WITH AN IGNITION DEVICE WHICH AUTOMATICALLY LIGHTS THE BURNER. DO NOT TRY TO LIGHT THE BURNER BY HAND.
- B. BEFORE LIGHTING: SMELL ALL AROUND THE APPLIANCE AREA FOR GAS. BE SURE TO SMELL NEXT TO THE FLOOR BECAUSE SOME GAS IS HEAVIER THAN AIR AND WILL SETTLE ON THE FLOOR.
- WHAT TO DO IF YOU SMELL GAS
- DO NOT TRY TO LIGHT ANY APPLIANCE.
 - DO NOT TOUCH ANY ELECTRIC SWITCH; DO NOT USE ANY PHONE IN YOUR BUILDING.
 - IMMEDIATELY CALL YOUR GAS SUPPLIER FROM A NEIGHBOR'S PHONE. FOLLOW THE GAS SUPPLIER'S INSTRUCTIONS.
 - IF YOU CANNOT REACH YOUR GAS SUPPLIER, CALL THE FIRE DEPARTMENT.
- C. USE ONLY YOUR HAND TO TURN THE MAIN MANUAL GAS VALVE HANDLE. NEVER USE TOOLS. IF THE HANDLE WILL NOT TURN BY HAND, DON'T TRY TO REPAIR IT, CALL A QUALIFIED SERVICE TECHNICIAN. FORCE OR ATTEMPTED REPAIR MAY RESULT IN A FIRE OR EXPLOSION.
- D. DO NOT USE THIS APPLIANCE IF ANY PART HAS BEEN UNDER WATER. IMMEDIATELY CALL A QUALIFIED SERVICE TECHNICIAN TO INSPECT THE APPLIANCE AND TO REPLACE ANY PART OF THE CONTROL SYSTEM AND ANY GAS CONTROL WHICH HAS BEEN UNDER WATER.
- E. DO NOT OPERATE APPLIANCE UNLESS UNIT IS FILLED WITH WATER AND WATER LINES ARE FULLY OPEN.

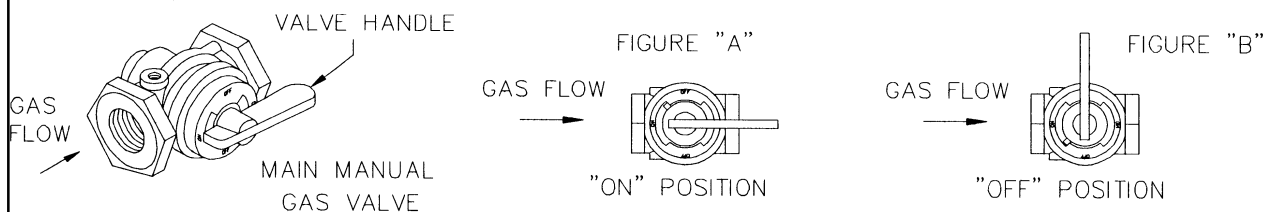

OPERATING INSTRUCTIONS

1. STOP! READ THE SAFETY INFORMATION ABOVE ON THIS LABEL.
2. SET THE SYSTEM CONTROLLER TO THE LOWEST SETTING.
3. TURN POWER SWITCH ON APPLIANCE TO "OFF" POSITION (SWITCH LIGHT GOES OUT).
4. TURN MAIN MANUAL GAS VALVE TO "OFF" POSITION, (FIGURE "B"). THE VALVE IS "OFF" WHEN THE HANDLE IS PERPENDICULAR TO THE GAS FLOW DIRECTION.
5. THIS APPLIANCE IS EQUIPPED WITH AN IGNITION DEVICE WHICH AUTOMATICALLY LIGHTS THE BURNER. DO NOT TRY TO LIGHT THE BURNER BY HAND.
6. WAIT FIVE (5) MINUTES TO CLEAR OUT ANY GAS. THEN SMELL FOR GAS, INCLUDING NEAR THE FLOOR. IF YOU SMELL GAS,
 7. STOP! FOLLOW "B" IN THE SAFETY INFORMATION ABOVE ON THIS LABEL. IF YOU DON'T SMELL GAS, GO TO THE NEXT STEP.
 7. TURN MAIN MANUAL GAS VALVE TO "ON" POSITION, (FIGURE "A"). THE VALVE IS "ON" WHEN THE HANDLE IS PARALLEL TO THE GAS FLOW DIRECTION.
 8. TURN POWER SWITCH TO "ON" POSITION (SWITCH LIGHT COMES ON).
 9. SET THE SYSTEM CONTROLLER TO DESIRED SETTING.
 10. IF THE APPLIANCE WILL NOT OPERATE, FOLLOW THE INSTRUCTIONS "TO TURN OFF GAS TO THE APPLIANCE" AND CALL YOUR SERVICE TECHNICIAN OR GAS SUPPLIER.

TO TURN OFF GAS TO APPLIANCE

1. SET THE SYSTEM CONTROLLER TO THE LOWEST SETTING.
2. TURN POWER SWITCH ON APPLIANCE TO "OFF" POSITION (SWITCH LIGHT GOES OUT).
3. TURN MAIN MANUAL GAS VALVE TO "OFF" POSITION, (FIGURE "B"). THE VALVE IS "OFF" WHEN THE HANDLE IS PERPENDICULAR TO THE GAS FLOW DIRECTION.

ELECTRONIC HOT SURFACE IGNITION CONTROL BOARD

ALL MODELS - The WHC1502 ignition control board is a fully integrated, state of the art electronic control system. The ignition control board includes a microprocessor, which governs all temperature and ignition control functions for the appliance. Inherent in the design are the normal operating sequences and safety features associated with a gas ignition control system. The ignition control continuously performs various diagnostic tests to verify proper appliance and control operation. Should an unsafe condition occur, the control will shut down the burner and illuminate the appropriate diagnostic indicators on the Display Board, indicating a need for service. All operating programs are stored in permanent memory on the ignition control and a second programmable memory is used for retaining user-specific operating parameters in the event main power is ever interrupted.

Line Polarity Indicator

A green LED is mounted on the ignition control to indicate line voltage polarity is properly connected. When 120 VAC input power is properly connected to the Ignition Control Board, the green LED will illuminate. If an error is made when connecting 120 VAC input power, this LED will not light. Improperly connecting the input power may result in a false flame sensor failure.

Fuse Protection

The 24 VAC circuitry is protected with a 3 amp auto fuse. If the fuse opens, a red LED located near the fuse will light. If the red LED is illuminated, replace the fuse (recommended replacement part is Little fuse p/n 257003 automotive fuse). **Repeated failure of the fuse is an indication of possible damage to the ignition control board.**

NOTE: One extra fuse is supplied with the boiler.

Typical Control/Appliance Operating Sequence

1. When power is applied to the WHC1502 ignition control, the Display board will initially run through a self-diagnostic routine, and then go into its operating mode, displaying the temperature sensed at temperature probe #1 (Outlet).
2. If the ignition control board determines the actual outlet water temperature at the temperature sensing probe (probe #1) is below the programmed temperature set-point less the switching differential, and the thermostat circuit or tank probe circuit closes, call for heat is activated.
3. The ignition control board then performs selected system diagnostic checks. This includes confirming the proper state of the ECO/High Limit device, flow switch, and pressure switches.
4. If all checks are successfully passed, the circulating pump circuit is energized, then the combustion blower is energized for the 20 second pre-purge cycle.
5. When the pre-purge cycle is complete, the ignitor is energized. The pump and blower should continue to run.
6. The ignition control board will verify ignitor current. After the verification, the gas valve will open, allowing gas to enter the burner.
7. After an additional 1 second, the ignition control board will monitor the flame sense probe to confirm a flame is present. If a flame is not verified within 4 seconds, the gas valve is immediately closed, and the ignition control board will return to step 2, unless jumper J30 is in place (ON), see figure 2.

8. If a flame is confirmed, the control will enter the heating mode where it will continue heating until the set-point temperature is reached, and the thermostat circuit opens. At that point, the gas valve is closed and the control enters the post-purge and post-circulating cycles.
9. The combustion blower will run for a 25 second post purge cycle. When the post purge cycle is complete, the blower is de-energized and will coast to a stop. The circulating pump will continue with the post-circulate cycle for the selected amount of time, factory default is 45 seconds. See circulating pump adjustment procedure on page 5 and 6 of this manual.
10. The control now enters the idle state while continuing to monitor temperature and the state of other system devices. If the outlet temperature drops below the set-point value minus the switching differential, and the thermostat circuit or tank probe circuit closes, the control will automatically return to step 2 and repeat the entire operating cycle. During this idle state, if the control detects an improper operating state for external devices such as the ECO switch, air pressure switch, gas pressure switch, etc., the appropriate LED(s) on the Display Board will illuminate indicating the nature of the fault.

DIA-SCAN II DISPLAY BOARD OPERATING PROCEDURES

The Display Board provides a user-friendly interface to the WHC1502 Ignition Control Board. With the Display Board, the user can control appliance functions and view the overall operating status of the appliance. If an error condition occurs, the Display Board will scroll a message across the LED display, indicating the error code. Under normal operating conditions, the four digit LED display on the Display Board will continuously illustrate the water temperature sensed at temperature probe #1 (Outlet). The push buttons on the Display Board allow the user to program and view the desired water temperature set point. The Display Board is connected to the Ignition Control Board through a 6 conductor cable assembly with modular plug terminations. In addition, an 8 conductor modular jack on the Display Board allows for connecting a remote display board.

When power is applied to the WHC1502 System, the Display Board will initially run through a self-diagnostic test, and then display the Outlet temperature. To display a specific setting or temperature, press the SELECT push-button until the appropriate LED is illuminated (see figure 1). After 5 seconds, the Display Board will automatically revert to displaying the Outlet temperature. Pressing the ENTER/RESET push-button will hold the display in the indicated mode until the SELECT push-button is pressed.

With the Display Board, the user can make adjustments to many of the appliance's control features. This includes the following:

Options/Features Setting Procedures

- Set Appliance Temperature Set-point Value
- Set Appliance Switching Differential Value
- Select Appliance Post-Circulate Time
- Set Appliance Circulating Pump to Continuous ON Mode
- Check Appliance Cycle Count
- Control the water temperature in a storage tank

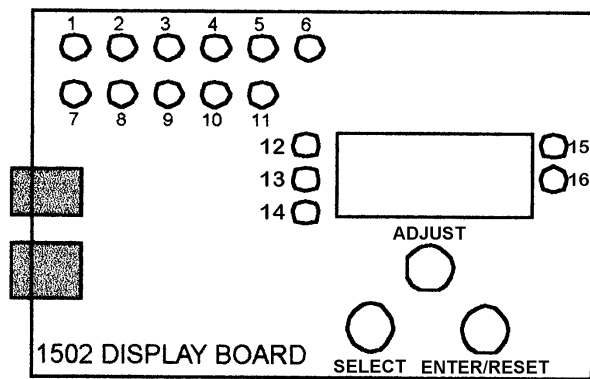

Figure 1. Dia-Scan II Display Board.

Green Status Lights

- LED 1: Call for Heat
- LED 2: Flow Switch
- LED 3: Pressure Switch
- LED 4: Ignitor Current
- LED 5: Gas Valve
- LED 6: Flame Sense

Red Fault Lights

- LED 7: Ignition Fail
- LED 8: Circulate Failure
- LED 9: Blower Failure
- LED 10: Blocked Inlet
- LED 11: Blocked Flue

Water Temperature Set Lights

- LED 12: Inlet Water Temperature *
- LED 13: Outlet Water Temperature
- LED 14: Inlet/Outlet Differential Temperature
- LED 15: Set-Point Temperature
- LED 16: Outlet/Set-Point Differential Temperature

* Defaults to tank probe temperature when tank probe is used.

Temperature Set-point Adjustment Procedure

The control board has a standard programmable temperature set-point range of 110°F to 240°F. The user can easily change the temperature set-point at any time by using the following procedure. In all cases, the boiler must be energized. The factory default setting is 180°F.

To change or view the current programmed temperature set-point value:

1. Press the SELECT push-button on the display board until both the Set-Pt LED (LED 15, see figure 1) and Outlet Water Temperature LED (LED 13, see figure 1) are illuminated.
2. The LED display will show the current set-point temperature.
3. Press and hold the ADJUST push-button. The displayed temperature will either increase or decrease. To alternate between increasing or decreasing the temperature, release then press and hold the ADJUST push-button.
4. When the desired set-point temperature is reached, release the ADJUST push-button.
5. Press the ENTER/RESET push-button once, this enters the selected set-point temperature into controller memory.
6. The appliance will now control the temperature to the desired set-point value.

NOTE: The boiler must complete a full cycle in order for the new setting to take effect. If the unit is turned off prior to a complete cycle the setting will be lost and the previous setting will remain in effect.

If the ADJUST push-button is held down long enough, the set-point will reach 110°F, the minimum value (or 240°F, the maximum value) and stop. At this point, if the desired set-point is not obtained, release the ADJUST push-button and depress it again. The set-point value will now restart at 110°F (240°F) and once again increase (decrease) in value for as long as the ADJUST push-button is pressed.

Switching Differential Adjustment Procedure

To facilitate proper operation and maximize appliance performance, the control has a programmable operating switching differential or "hysteresis" about the set point. This means a call for heat will become active when the water temperature measured at the outlet temperature sensing probe (Probe #1) drops to the set-point value minus the switching differential value. The burner will remain on until the water temperature measured at probe #1 reaches the set-point value. The switching differential value is fully programmable from 5°F to 50°F using the push-button(s) located on the Display Board. The default is set at 20°F.

To change or view the current programmed switching differential:

1. Press the SELECT push-button on the display board until the Set-Pt differential LED (LED 16, see figure 1) is illuminated.
2. The LED display will show the current switching differential.
3. Press and hold the ADJUST push-button. The displayed value will either increase or decrease. To alternate between increasing or decreasing the switching differential, release then press and hold the ADJUST push-button.
4. When the desired switching differential is reached, release the ADJUST push-button.
5. Press the ENTER/RESET push-button once, this enters the selected switching differential value into controller memory.
6. The appliance will now control temperature utilizing the desired switching differential value.

If the ADJUST push-button is held down long enough, the switching differential setting will reach 5, the minimum value (or 50, the maximum value) and stop. At this point, if the desired switching differential is not obtained, release the ADJUST push-button and depress it again. The switching differential value will now restart at 5 (50) and once again increase (decrease) in value for as long as the ADJUST push-button is pressed.

Circulating Pump Adjustment Procedure

The Controller is factory set with a 45 second post circulate function. Using the Display Board, the user has the capability to choose between a 45, 90, or 180 second post circulate time period, or turn the pump on continuously. This provides flexibility in selecting the post circulate time to meet specific application requirements, and improves the efficiency of the circulating pump operation.

To change or view the current programmed post-circulating time:

1. Press the SELECT push-button on the display board until the LED display reads OPt (Options).
2. To enter into the options mode, press the ENTER/RESET push-button.
3. The display will illustrate Circ. Enter this mode by pressing the ENTER/RESET push-button.
4. The display will now illustrate the current post circulate time. Press the ADJUST push-button to select the desired post circulate time (45, 90, 180, On).
5. When you have selected the desired post circulate time mode, press the ENTER/RESET push-button once, this enters the selected post circulate time into controller memory.
6. The display will automatically resort to illustrating the outlet temperature.

Display Current Mode

In this mode, the Display Board will illustrate the current functional step in the appliance operational sequence. For example, if the appliance is performing Ignitor Warm-up, the display will illustrate IGnt. To enter into this mode, perform the following steps:

1. Press the SELECT push-button on the display board until the LED display reads OPt (Options).
2. To enter into the options mode, press the ENTER/RESET push-button.
3. The display will illustrate Circ. Press the SELECT push-button until the display illustrates StEP. Enter this mode by pressing the ENTER/RESET push-button.
4. The display will illustrate the current appliance operating step.
5. The display will automatically resort to illustrating the outlet temperature. To keep the display in the Display Step Mode, press ENTER/RESET twice in step 3.

Display Message	Appliance Mode
IdLe	Idle state
NoSn	Wait for No Sensor Inputs
CrSn	Wait for Circulate Sense
Circ	Circulate Pump is ON
PrSn	Wait for Blower Pressure Sense
PreP	Pre-Purge state
IGnt	Ignitor Warm-up
rEdn	Turn ON redundant Gas Valve relay
IAct	Turn ON Gas Valves
StAb	Turn OFF Ignitor and wait for Flame Sense Stabilization
HEAt	Heat Mode
PoPC	Post Purge and Post Circulate
Po C	Post Circulate

Display Total Cycle Count

The Main Control Board counts the number of cycles the appliance has operated. In the Main Control Board, a cycle is counted every time the gas valve is energized. To access this number, perform the following procedure:

1. Press the SELECT push-button on the display board until the LED display reads OPt (Options).
2. To enter into the options mode, press the ENTER/RESET push-button.

3. The display will illustrate Circ. Press the SELECT push-button until the display illustrates Count. Enter this mode by pressing the ENTER/RESET push-button.
4. The display will now illustrate the current number of cycles the appliance has cycled through.
5. The display will automatically resort to illustrating the outlet temperature.

TANK PROBE INSTALLATION PROCEDURE

A tank probe is supplied with each hot water supply boiler. When installed on a tank, the inlet water temperature on the Dia-Scan II will default to the tank temperature. **See figures 2 and 3 to add the tank jumper to the control board so that the tank probe is active.**

A tank probe is NOT supplied with the hydronic heating boilers (GB's). Therefore, a loop or operating thermostat must be provided. This field-supplied operating thermostat should be wired to the BROWN wires at the junction box. The jumper at location J33 on the control board must NOT be on. Refer to figures 2 and 3 for the location of this jumper.

Tank Probe Set-Point Adjustment

When tank probe is installed in a storage water tank, and the tank probe is used with the WHC1502 system, the controller will monitor and control the temperature of the water at the tank probe location. Setting the tank probe set-point temperature is accomplished through the Display Board control panel. The standard programmable temperature range for the indirect water tank is 110°F to 190°F. The switching differential of the probe is fixed at 5°F.

Tank Probe Temperature Set-point Adjustment Procedure

The user can easily change the tank probe water temperature set-point at any time by using the following procedure:

1. Press the SELECT push-button on the display board until both the Set-Pt LED (LED 15, see figure 1) and Inlet Water Temperature LED (LED 12, see figure 1) are illuminated.
NOTE 3: When a tank probe is connected to the board at location CN10, the Inlet Water Temperature LED defaults to Tank Water Temperature.
2. The LED display will show the current tank set-point temperature.
3. Press and hold the ADJUST push-button. The displayed temperature will either increase or decrease. To alternate between increasing or decreasing the temperature, release then press and hold the ADJUST push-button.
4. When the desired set-point temperature is reached, release the ADJUST push-button.
5. Press the ENTER/RESET push-button once, this enters the selected tank set-point temperature into controller memory.
6. The appliance will now control the tank water temperature to the desired set-point value.

If the ADJUST push-button is held down long enough, the set-point will reach 110°F, the minimum value (or 190°F, the maximum value) and stop. At this point, if the desired set-point is not obtained, release the ADJUST push-button and depress it again. The set-point value will now restart at 110°F (190°F) and once again increase (decrease) in value for as long as the ADJUST push-button is pressed.

Diascan II cable connection point

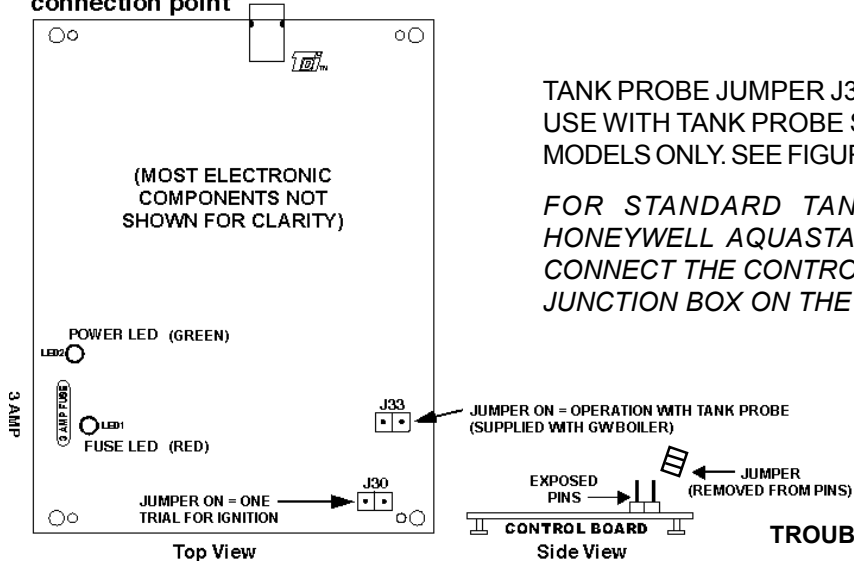

TANK PROBE JUMPER J33 IS ON AS DEFAULT, READY FOR USE WITH TANK PROBE SUPPLIED WITH THE BOILER (GW MODELS ONLY. SEE FIGURE 3 FOR CONNECTION DIAGRAM).

FOR STANDARD TANK CONTROLS (e.g., 24 VAC HONEYWELL AQUASTAT) REMOVE THIS JUMPER AND CONNECT THE CONTROL TO THE BROWN WIRES IN THE JUNCTION BOX ON THE BACK OF THE BOILER.

TROUBLESHOOTING IGNITION SYSTEM

Figure 2. WHC 1502 Ignition Control Board

⚠ DANGER

HOT WATER TEMPERATURES REQUIRED FOR AUTOMATIC DISHWASHER AND LAUNDRY USE CAN CAUSE SCALD BURNS RESULTING IN SERIOUS PERSONAL INJURY AND/OR DEATH. THE TEMPERATURE AT WHICH INJURY OCCURS VARIES WITH THE PERSON'S AGE AND TIME OF EXPOSURE. THE SLOWER RESPONSE TIME OF DISABLED PERSONS INCREASES THE HAZARDS TO THEM. NEVER ALLOW SMALL CHILDREN TO USE A HOT WATER TAP, OR TO DRAW THEIR OWN BATH WATER. NEVER LEAVE A CHILD OR DISABLED PERSON UNATTENDED IN A BATHTUB OR SHOWER.

THE WATER HEATER SHOULD BE LOCATED IN AN AREA WHERE THE GENERAL PUBLIC DOES NOT HAVE ACCESS TO SET TEMPERATURES.

It is recommended that lower water temperatures be used to avoid the risk of scalding. It is further recommended, in all cases, that the water temperature be set for the lowest temperature which satisfies the user's hot water needs. This will also provide the most energy efficient operation of the water heater and minimize scale formation.

SETTING THE WATER HEATER TEMPERATURE AT 120°F WILL REDUCE THE RISK OF SCALDS. Some states require settings at specific lower temperatures. Table 1 below shows the approximate time-to-burn relationship for normal adult skin.

Table 1: Risk of Scalds

Temperature Setting	Time to Produce 2nd & 3rd Degree Burns on Adult Skin
Over 170°F	Nearly instantaneous
160°F	About 1/2 second
150°F	About 1-1/2 seconds
140°F	Less than 5 seconds
130°F	About 30 seconds
120°F or less	More than 5 minutes

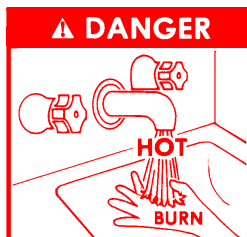

Display Board LED Indicators

The Display Board contains eleven (11) solid state LED indicators for viewing various states of appliance operation and for troubleshooting if problems occur. Under normal operating conditions, the appropriate LED's will sequence with steady illumination according to the particular appliance operating state. In cases where problems or a lockout occurs, the appropriate LED's will illuminate indicating the general area where the problem exists.

A description of the LED's and their corresponding functions are as follows.

LED	Controller Function
Call for Heat	Monitors Outlet water temperature minus Switching Differential and thermostat circuit or tank probe circuit. LED is ON when the temperature at Outlet Water Probe is less than the set-point minus the switching differential, and the thermostat circuit or tank probe circuit is closed.
Flow Switch	Monitors the condition of the flow switch. LED is ON when the flow switch closes, indicating water flow through the system.
Pressure Switch	Monitors the condition of the pressure switch(s). LED is ON when the pressure switch(s) are in their correct state.
Ignitor Current	Monitors current flow through the ignitor element. LED is ON when current flow through the ignitor is sensed.
Gas Valve	Monitors Gas Valve output. LED is ON when the output relays supplying power to the gas valve(s) is closed.
Flame Sense	Monitors the Flame Sense Rod. LED is ON when a signal from the flame rod is sufficient to indicate flame.
Blocked Inlet	Indicates a blockage or interference at the appliance air inlet.
Blocked Flue	Indicates a blockage or interference at the appliance flue.
Blower Fail	Indicates an error/malfunction in the blower motor circuit.
Circulate Fail	Indicates an error/malfunction in the circulating pump circuit.
Ignition Fail	Indicates a malfunction in the ignition system circuit.

Troubleshooting

The WHC1502 Series Control System has many inherent diagnostic and fault detection routines built into its operating hardware and software. These routines, in conjunction with the four (4) digit LED display and eleven (11) LED status indicators on the Display Board, can greatly assist any service person in quickly pinpointing the source of a problem which may occur within the appliance. Under certain circumstances, multiple LED's will illuminate to better pinpoint the target area(s).

The following list defines the error code messages that scroll across the LED display:

ERROR MESSAGE	REPORTED ERROR
OPEn InLEt ProbE	No probe detected at connector CN1 on Control Board.
OPEn OutLEt ProbE	No probe detected at connector CN2 on Control Board.
Circulation FAIL	No flow detected at flow switch.
Inducor FAIL	No pressure detected at pressure switch.
FLAmE SenSE FAIL	Flame sense detected before gas valve is turned on.
SenSor FAIL	One of the sensors, Flow, Pressure, Hi Gas, or Lo Gas was not in the correct state.
Ignitor FAIL	No Ignitor current sensed.
No Ignition	Flame not detected after 1 or 3 tries.
ECO FAIL	ECO/High Limit switch opened.
Control FAIL	Relay did not open or close properly.

BLOCKED VENT SHUT-OFF SYSTEM

The Boiler is equipped with a blocked vent shut-off system which will close the gas valve and shut off the main burner gas when there is excessive pressure in the vent system due to a partially or completely blocked vent system. The DIA-SCAN II display on the front panel will indicate this failure condition.

DO NOT ATTEMPT TO OPERATE THE BOILER if this situation occurs. Shut the boiler off before performing all the steps shown in "TO TURN OFF GAS TO APPLIANCE" section of the Lighting and Operating Instructions.

Contact a qualified service agent to inspect the unit and vent system and correct the problem.

VENT SYSTEM

The flue products are corrosive in nature and if the boiler is vented horizontally the flue gases are at a higher pressure than the

surrounding air pressure. Inspection of the boiler and vent system is necessary to insure that flue gas leakage to the surrounding area does not occur.

Inspect the external surfaces of the vent system every 3 months for corrosion and leakage. Inspect the vent terminations for corrosion and foreign matter which may be blocking the exhausting flue products. Call a qualified service agent to replace or repair any corroded or leaking parts.

Qualified service agent must inspect internal surfaces of the vent system and the boiler at least once a year.

BURNER SYSTEM

To maintain safe operation and the greatest efficiency for the boiler, observe the burner flame through the observation port on the left jacket panel, once a month for proper flame characteristics.

The burners should display the following characteristics:

- Provide complete combustion of gas.
- Cause rapid ignition and carry over across all burners and across the entire burner.
- Give quiet operation during ignition, burning and extinction.
- Cause no excessive lifting of flames from the burner ports.

If the preceding characteristics are not evident, check for accumulation of lint or other foreign material that restricts the inlet air or burner ports. Ensure there is the proper amount of air to the burner. Flame lifting from the burner is caused by too much air to the burner.

The burners must be inspected by a qualified service technician at least once a year.

DO NOT STORE COMBUSTIBLE MATERIALS, GASOLINE, OR OTHER FLAMMABLE VAPORS, LIQUIDS IN THE AREA OF THE APPLIANCE. NONCOMPLIANCE MAY RESULT IN FIRE OR EXPLOSION. DO NOT OBSTRUCT THE FLOW OF COMBUSTION OR VENTILATION AIR TO THE APPLIANCE.

CHEMICAL VAPOR CORROSION

Boiler corrosion and component failure can be caused by airborne chemical vapors. Spray can propellants, cleaning solvents, refrigerants, calcium or sodium chloride (water softener salts), waxes, and process chemicals are typical compounds that are potentially corrosive. These materials are corrosive at very low concentration levels with little or no odor to reveal their presence. Products of this sort should not be stored near the boiler. Air which is brought in contact with the boiler should not contain any of these chemicals. The boiler should be provided with air from outdoors when installed in environments having corrosive atmospheres.

CIRCULATION PUMP

Refer to the pump manufacturer's schedule of maintenance for frequency and method of lubricating the pump and motor. Inspect the pump once a month for leaky mechanical seals and/or O-rings and loose or damaged components. Contact a qualified service agent to replace or repair parts as required.

NOTES:

1. Use either the tank probe or an external control (24 VAC) for system control, but not both.
2. If any of the original wire as supplied with the appliance must be replaced, it must be replaced with 18 GAUGE, 105°C wire or equivalent.

BURKAY GENESIS CONNECTION DIAGRAM

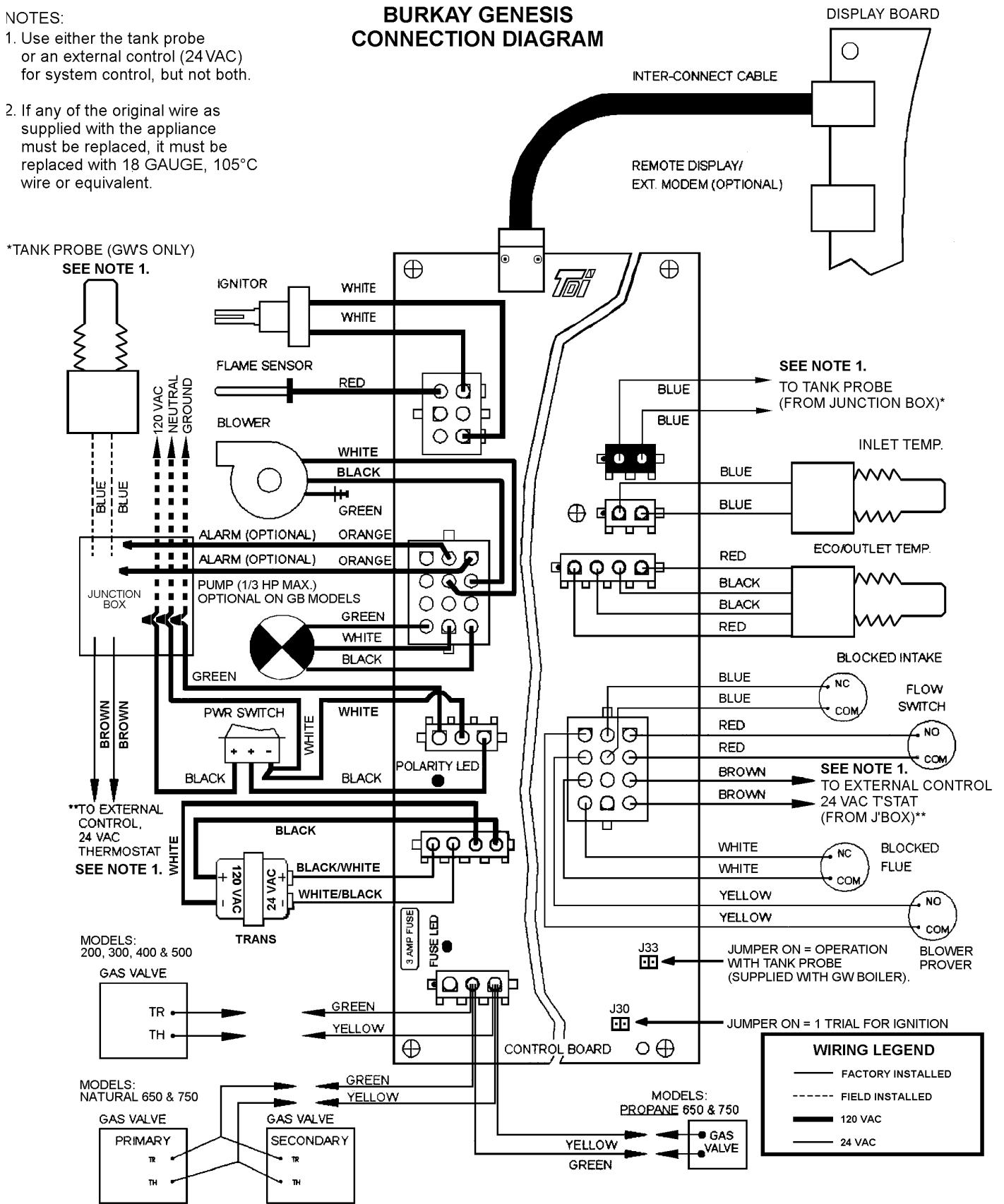

FIGURE 3. POINT TO POINT WIRING DIAGRAM

NEW BOILER LIMITED WARRANTY

A. O. Smith Corporation, the warrantor, extends the following LIMITED WARRANTY to the owner of this hydronic boiler:

1. If within TEN years after initial installation of the boiler, the heat exchanger shall prove upon examination by the warrantor to be defective in material or workmanship, the warrantor, at his option, will exchange or repair such part or portion. This term is reduced to FIVE years if this boiler is used for volume hot water supply purposes other than hydronic space heating.
 - a. This warranty is extended to the owner for all other parts or portion during the FIRST year following initial installation of this boiler.
 - b. The warranty on the repair or replacement of the part or portion will be limited to the unexpired term of the original warranty.

2. **CONDITIONS AND EXCEPTIONS**

This warranty shall apply only when the boiler is installed in accordance with local plumbing and building codes, ordinances and regulations, the printed instructions provided with it and good industry practices. In addition, an appropriately sized safety relief valve certified to the ASME Boiler and Pressure Vessel Code must have been installed and fresh water used for filling and makeup purposes;

- a. This warranty shall apply only when the boiler is used:
 - (1) at temperatures not exceeding the maximum setting of its operative and/or high limit control;
 - (2) at water pressure not exceeding the working pressure shown on the boiler;
 - (3) when filled with boiler water, free to circulate at all times and with the heat exchanger free of damaging scale deposits;
 - (4) in a noncorrosive and non-contaminated atmosphere;
 - (5) in the United States, its territories or possessions, and Canada;
 - (6) at a water velocity flow rate, not exceeding or below the Boiler's designed flow rates;
- b. Any accident to the boiler, any misuse, abuse (including freezing) or alteration of it, any operation of it in a modified form will void this warranty.

3. **SERVICE AND REPAIR EXPENSE**

Under this limited warranty the warrantor will provide only a replacement part. The owner is responsible for all other costs. Such costs may include but are not limited to:

- a. Labor charges for service removal, repair or reinstallation of the component part;
- b. Shipping, delivery, handling, and administrative charges for forwarding the replacement part from the nearest distributor and returning the claimed defective part to such distributor.
- c. All cost necessary or incidental for any material and/or permits required for installation of the replacement.

4. **LIMITATIONS ON IMPLIED WARRANTIES**

Implied warranties, including any warranty of merchantability imposed on the sale of this boiler under state law are limited to one (1) year duration for the boiler or any of its parts. Some states or provinces do not allow limitations on how long an implied warranty lasts, so the above limitation may not apply to you.

5. **CLAIM PROCEDURE**

Any claim under the warranty should be initiated with the dealer who sold the boiler, or with any other dealer handling the warrantor's products. If this is not practical, the owner should contact:

U.S. Customers
A. O. Smith Water Products Company
5621 West 115th Street
Alsip, IL 60803
Telephone: 800 323-2636

Canadian Customers
A. O. Smith Enterprises Ltd.
P. O. Box, 310 - 768 Erie Street
Stratford, Ontario N5A 6T3
Telephone: (519) 271-5800

- a. The warrantor will only honor replacement with identical or similar parts thereof which are manufactured or distributed by the warrantor.
- b. Dealer replacements are made subject to in-warranty validation by warrantor.

6. **DISCLAIMERS**

NO OTHER EXPRESS WARRANTY HAS BEEN OR WILL BE MADE ON BEHALF OF THE WARRANTOR WITH RESPECT TO THE BOILER OR THE INSTALLATION, OPERATION, REPAIR OR REPLACEMENT OF THE BOILER. THE WARRANTOR SHALL NOT BE RESPONSIBLE FOR WATER DAMAGE, LOSS OF USE OF THE UNIT, INCONVENIENCE, LOSS OR DAMAGE TO PERSONAL PROPERTY OR OTHER CONSEQUENTIAL DAMAGE. THE WARRANTOR SHALL NOT BE LIABLE BY VIRTUE OF THIS WARRANTY OR OTHERWISE FOR DAMAGE TO ANY PERSONS OR PROPERTY, WHETHER DIRECT OR INDIRECT, AND WHETHER ARISING IN CONTRACT OR TORT.

- a. Some states or provinces do not allow the exclusion or limitation of the incidental or consequential damage, so the above limitations or exclusions may not apply to you.
- b. This warranty gives you specific legal rights, and you may also have other rights which vary from state to state or province to province.

Fill in the following for your own reference. Keep it. Registration is not a condition of warranty. The model and serial number are found on the boiler's rating plate.

Owner _____

Installation Address _____

City and State or Province _____

Date Installed _____ Model No. _____ Serial No. _____

Dealer's Name _____

Dealer's Address _____ Phone No. _____

FILL IN WARRANTY AND KEEP FOR FUTURE REFERENCE