



DAVE LENNOX
signature
COLLECTION

Home Comfort Systems



O23V

Variable speed for superior comfort



HOME COMFORT SYSTEMS
Innovation never felt so good.™



Dave Lennox *Signature*® Collection O23V Oil Furnace

Innovation never felt so good.™

Variable speed operation assures comfort, efficiency and considerable noise reduction

Quality components ensure long-lasting reliability

Built to exacting standards with the highest-quality components, the Dave Lennox *Signature*® Collection O23V oil furnace is a superior way to keep your home warm and comfortable.

QUIET, EFFICIENT, COMFORTABLE HEATING

Every innovation speaks to quality—from its innovative variable speed motor to its insulated steel cabinet. For those who refuse to compromise, the O23V oil furnace is the premium choice, inside and out.

Innovative

Uses variable speed technology to improve comfort and indoor air quality

A variable speed motor moves at different speeds to precisely control the flow of air throughout your home. Better airflow control means a better balance of comfort.

When the variable speed motor increases speed, it does so smoothly and gradually. During summer months, this allows your air conditioner to remove moisture from the air for improved comfort and better indoor air quality.

VARIABLE SPEED MOTOR

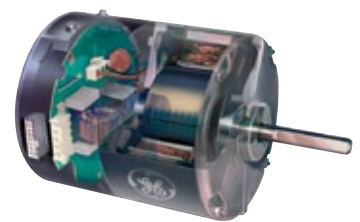

EFFICIENCY RATING

Up to 83% AFUE (Annual Fuel Utilization Efficiency).

WARRANTY*

Limited lifetime warranty on the heat exchanger.

10-year limited warranty on all remaining covered components.

*Applies to residential applications only. See actual warranty certificate for details.

Efficient

Delivers significant energy savings all year

The O23V has a heating efficiency of up to 83% AFUE. Compared to an older furnace, the O23V can dramatically reduce your utility bills.

As an added benefit, the O23V's variable speed motor uses about two-thirds less electricity than a standard motor. During cooling operation, this typically results in an efficiency gain of 1 SEER (Seasonal Energy Efficiency Ratio), which can add to your energy savings.

3-YEAR HEATING SAVINGS

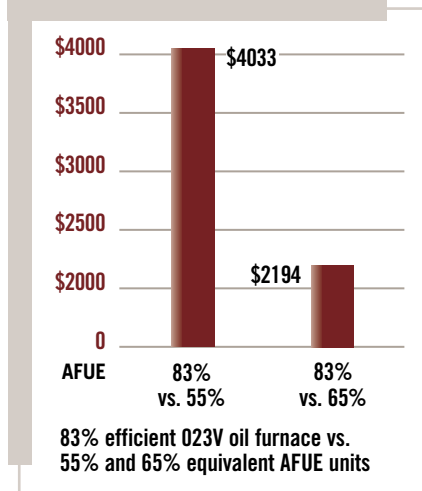

This chart depicts potential energy savings you can expect from the O23V furnace versus older furnaces with lower efficiency ratings. Criteria used in this example are 2,000 full-load heating hours, with a 80,000-Btuh heating design load and \$1.90 per gallon for oil. Your actual savings will vary depending on the weather, local fuel rates and your lifestyle.

Source: Energy Information Administration, U.S. Department of Energy national average energy rates, 2005 forecast.

Quiet

Exclusive SilentComfort™ technology maximizes your comfort while minimizing sound

The variable speed motor ramps up to speed slowly, so there's no sudden blast of air at startup. A specially insulated cabinet further reduces operating sound.

Healthier

Slowly circulates air for better indoor air quality

When you set your thermostat to "FAN," the O23V continues to slowly circulate air throughout your home. That means you can run the fan constantly without substantially increasing operating costs.

It also means better indoor air quality—low-speed fan operation increases the effectiveness of your filters, allowing them to capture and remove more contaminants.

VARIABLE SPEED OPERATION

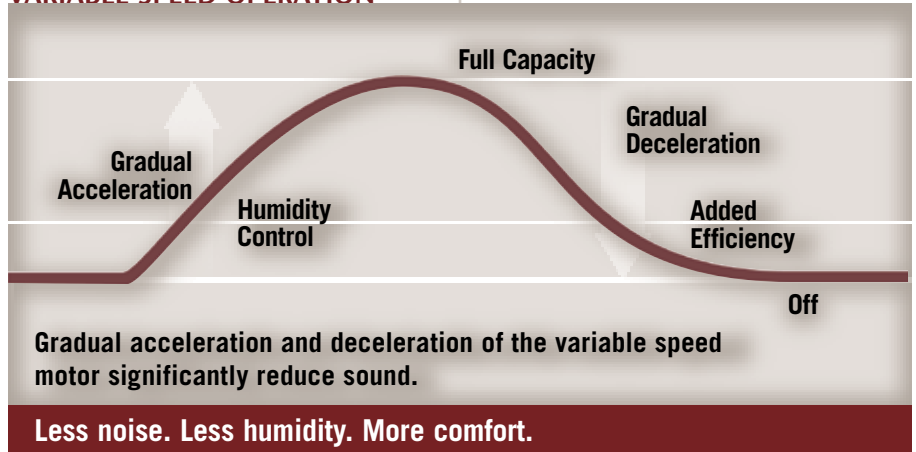



CONTINUOUS COMFORT NETWORK

The **O23V Variable Speed Furnace** is designed to easily integrate with other quality Lennox® products, providing a total home comfort solution:

XC21 Air Conditioner is the most quiet and efficient central air conditioner you can buy.**

PureAir™ Air Purification System cleans the air in your home better than any other single system you can buy.

Harmony III™ Zoning System provides customized, room-to-room comfort.

Dave Lennox Signature® Collection O23V Specifications			
O23V Upflow	V2/3-70/90	V3/4-105/120	V5-140/154
AFUE	83%	81%	81%
Dimensions HxWxD (in.)	54 x 19-1/2 x 30-5/8	54 x 19-1/2 x 30-5/8	54 x 22-1/2 x 33-1/8
HxWxD (mm)	1372 x 495 x 778	1372 x 495 x 778	1372 x 572 x 841

Note: Due to Lennox' ongoing commitment to quality, all specifications, ratings and dimensions are subject to change without notice.

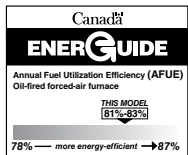

Lennox is proud of the fact that these products have earned the Good Housekeeping Seal.

**A combination of sound ratings established per ARI's test standard: 270 and efficiency ratings established per ARI's test standard: ANSI/ARI 210/240-2005.

INNOVATIVE FEATURES FOR ENHANCED COMFORT AND EFFICIENCY

Heavy-Gauge Steel Heat Exchanger –

Allows air to glide evenly over its smooth surface for maximum heating efficiency.

Innovative Combustion Chamber –

Constructed from alumina-silica ceramic fiber, provides quiet operation and high efficiency.

Beckett Burner –

Delivers super-efficient combustion for greater fuel economy. It's one of the finest, most trouble-free burners in the industry.

Heavy-Duty Fuel Pump –

Provides quiet, reliable operation with fast shutoff of oil flow.

Variable Speed Motor –

Highly efficient motor quietly controls flow of air for added humidity control, indoor air quality and comfort.

Insulated Blower Compartment –

Minimizes operating sounds.

Durable, Insulated Steel Cabinet –

Built to last and coated with a high-quality paint finish.

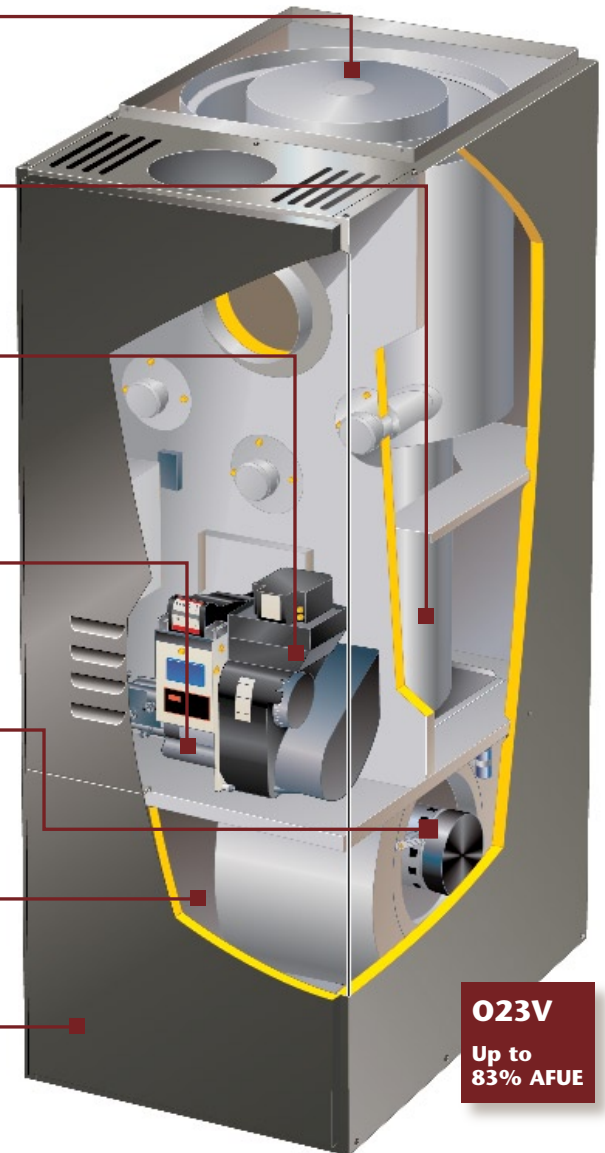

O23V
Up to
83% AFUE

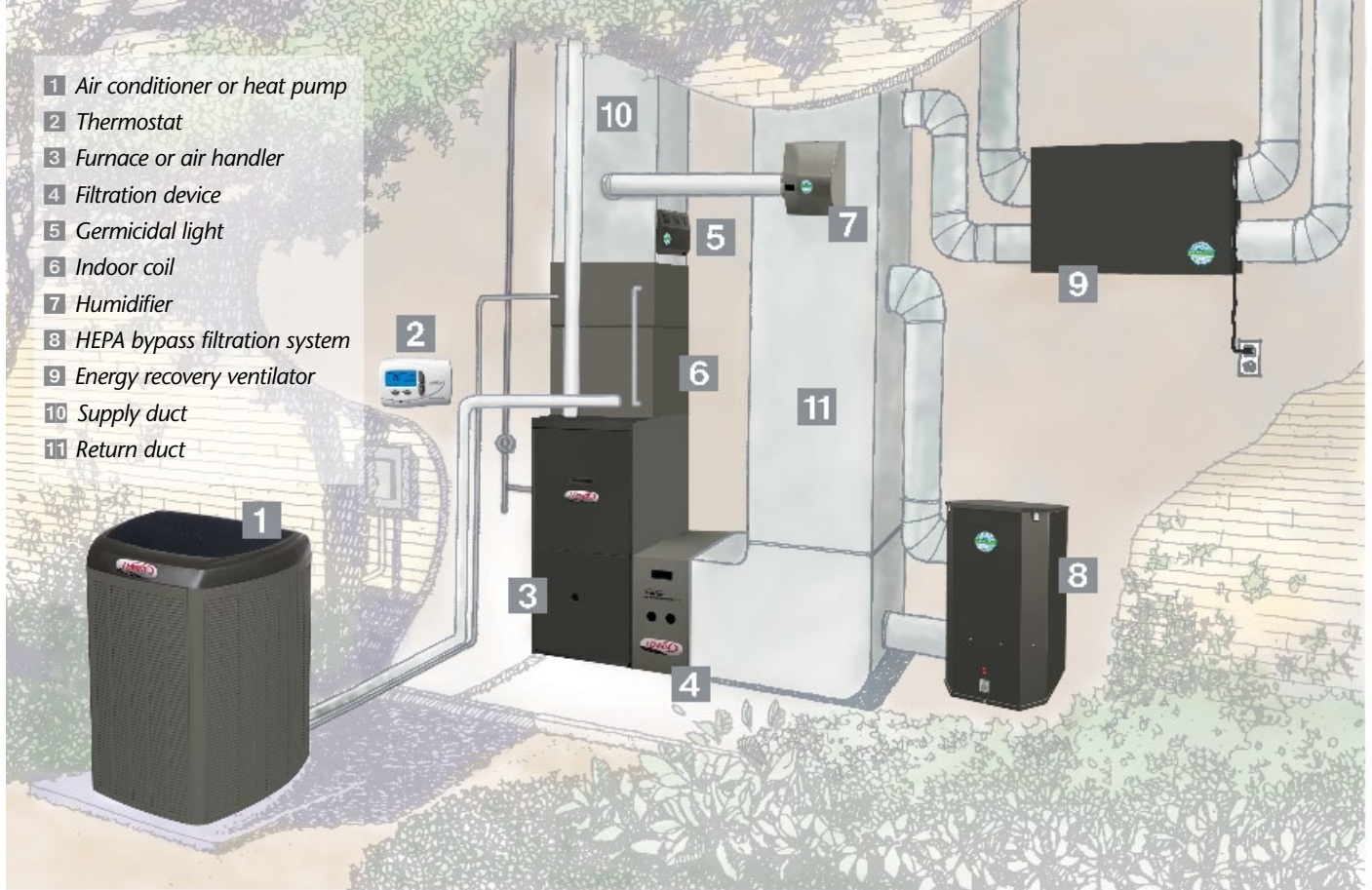

- 1 Air conditioner or heat pump
- 2 Thermostat
- 3 Furnace or air handler
- 4 Filtration device
- 5 Germicidal light
- 6 Indoor coil
- 7 Humidifier
- 8 HEPA bypass filtration system
- 9 Energy recovery ventilator
- 10 Supply duct
- 11 Return duct

CUSTOMIZE YOUR COMFORT

Lennox® heating, cooling and Healthy Climate® indoor air quality products are designed to provide efficient, economical comfort—not only as individual units, but also together as an integrated system. This combined network of products delivers on every comfort count, from consistent temperatures and balanced humidity to improved indoor air quality.

DEALERS YOU CAN COUNT ON

Choosing the right dealer for your home's heating, cooling and air quality needs is every bit as important as choosing the right brand. We think you'll agree our independent dealers are a big reason you can count on quality customer service whenever you call. Your Lennox dealer's dedication to quality shows in his knowledge, training and expertise in designing the right system for your home, installing it properly and keeping it running perfectly for many years to come.



LENNOX

HOME COMFORT SYSTEMS
Innovation never felt so good.™

© Lennox Industries Inc. 2005

Visit us at www.lennox.com, or contact us at 1-800-9-LENNOX.