

FANTASEA
Line

FL-3 + FL-4

For Nikon Coolpix L2, L3 and L4
Digital Cameras

OPERATORS MANUAL

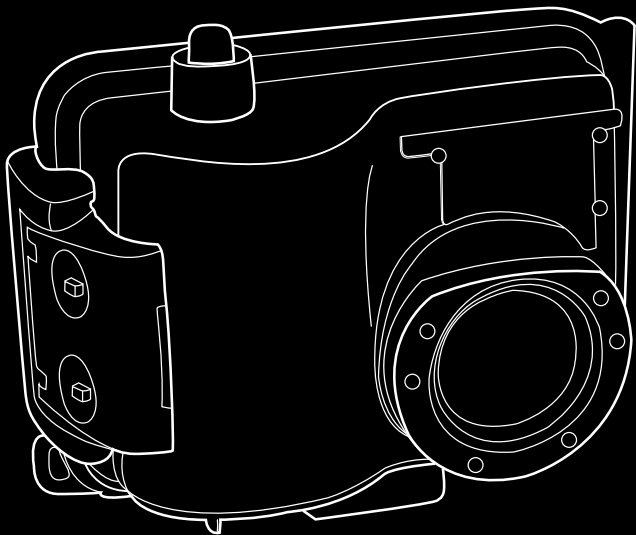

Manual for the FL-3 + FL-4

TABLE OF CONTENTS

● Table of contents.....	pg.1
● General information:	pg.2
The Fantasea FL-3 + FL-4 housing:	pg.2
Fantasea FL-3 + FL-4 USES:	pg.2
General Camera description:	pg.7
Nikon Coolpix L2, L3, L4 feature highlights:	pg.8
● Using the fantasea FL-3 and FL-4 housing.....	pg.9
Opening the Housing:	pg.9
Inserting Camera:	pg.9
Checking the gasket:	pg.10
Closing the housing:	pg.11
● Viewing the subject:	pg.11
Taking the picture:	pg.12
Choosing image files:	pg.12
● Battery life:	pg.12
● Using the flash:	pg.13
Accessory slave flash:	pg.13
Lens accessories:	pg.14
● Shooting Techniques:	pg.15
Exposure Modes: (Pre-set before camera insertion).....	pg.15
Zoom control:	pg.15
Macro focus:	pg.15
Quick review:	pg.15
Camera standby mode:	pg.16
● Care & Maintenance:	pg.16
● Flood insurance:	pg.18

● General Information:

The Fantasea FL-3 + FL-4 housing:

Fantasea has specially designed a housing for the Nikon Coolpix L2, L3 and L4 cameras. The housings, dedicated to these three cameras (the L2 and L3 are physically identical—the L4 slightly wider), insure the most compact design for easy handling and accurate access to camera functions through the critical placement of push-button controls.

The FL3 and FL4 contain all essential control functions: Mode, Menu, Zoom/Wide angle, Macro, Flash on/off, Exposure mode, Review, Delete, White Balance, Video/Still and more. The FL-3 + FL-4 housing provide a built in Flash Diffuser and an anti-glare hood over the LCD screen as well. This housing is ideal for outdoor and underwater photographers who enjoy the camera's automatic exposure features for capturing fast action pictures easily and creatively.

Fantasea FL-3 + FL-4 Uses:

The Fantasea FL-3 + FL-4 housings are designed as underwater/outdoor camera housings. They have a working depth of 130 feet/40 meters. Underwater photographers can dive or snorkel and capture all the excitement of this fascinating world, while outdoor photographers also have the option of capturing the action of such activities as white water and paddle sports, sailing and boating, surfing, fishing and hunting, backpacking and camping, and for family activities around the swimming pool or at the beach. The Fantasea FL-3 + FL-4 will protect those Coolpix cameras from water, sand, dust, and other damaging elements.

Top/Front Side of Housing

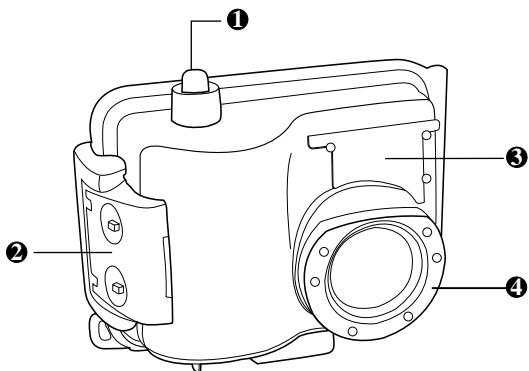

Back Side of Housing Buttons

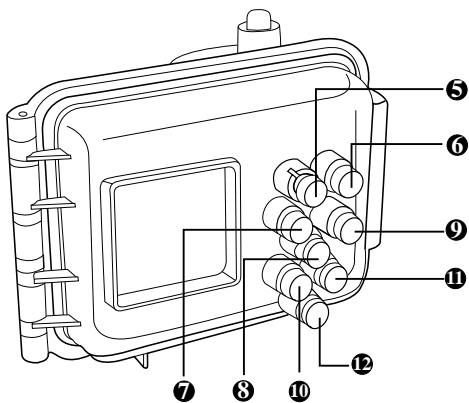

Numbered description below refers to corresponding numbers on above graphic.

1: Shutter Release button:

This is a two stage shutter-release button. First lightly press the shutter-release button halfway, stopping when you feel minimal resistance. Once the camera has focused, press the shutter-release button the rest of the way down to release the shutter and take the picture.

2: Buckle to secure housing:

Refer to the section "Using the Fantasea FL-3 and FL-4 Housing" on how to open and close the camera housing.

3: Removable Flash diffuser:

To diffuse the flash's intensity [the internal flash]. See the section on "Accessory Slave Flash" for additional information.

4: Lens Port:

Refer to the section "Inserting Camera" for useful information.

5 & 6: Zoom Control/Playback zoom and Thumbnail playback:

The zoom control is used to frame subjects in the monitor. Select W to zoom out, increasing the area visible in the frame. Select T to zoom up to 3x so that the subject fills a larger area of the frame. Pressing T for about 2 seconds at 3x zoom will trigger the digital zoom, allowing subject to be magnified up to 4x more. Note that unlike the optical zoom, the digital zoom will not increase the amount of detail visible in the picture—they are simply enlarged producing a slightly grainy image.

Pressing the W button in full-frame playback displays pictures in contact sheets whereas pressing the T button can be used to zoom in on pictures during full-frame playback.

7: Menu button:

Menus are available for shooting, playback, movies and camera set up. Press the menu button to display the menus; press again to return to shooting or playback mode.

- To display the Shooting menu, select the auto mode [button 12] and press the Menu button.
- For Playback menu, the playback mode must be selected [button 10] and press the Menu button.
- To display the Movie menu, select the movie mode [button 12] and press the Menu button.
- To display the Set Up menu, select setup from the Shooting menu.

8: Rotary Multi Selector:

The rotary multi selector is used to navigate the camera menus. Rotate in any direction to highlight items and press the center OK [#9] button to select. To cancel and return to the previous menu, press the rotary multi selector to the left. Highlighted options are found when pressing this rotary dial left, right or up and down.

Note!

When you make your choice using the Selector button, you may have to rotate the flange of this button away before swinging the OK button into position.

9: OK [Center] button:

This button authorizes the selections made when the Delete, Menu and Rotary Multi selector buttons are used. Must be swiveled into place when pressing OK and see that it does not interfere with the action of the Rotary Multi Selector button.

Note!

It may be necessary to make sure the flange of this OK button is swiveled away from the Rotary Selector button to facilitate selection with the Selector button. When you make your choice using the Selector button, you may want to rotate the flange of this button away before swinging the OK button into position.

10: Playback button:

Press this button to display a picture in the monitor. You can use the multi selector to view additional pictures in different parameters [quick scroll, reverse order etc.]; pressing this button again returns you to shooting mode.

To view pictures full-frame in monitor [full-frame playback], press this button [if camera is off, pressing the button for about a second will turn the camera on in playback mode].

11: Delete button:

To delete the current displayed picture in the monitor, press the Delete button. Two options appear: No or Yes. Highlight wanted option and press the OK center button [#9]. Additionally, pressing the Delete button in full-frame or thumbnail playback displays the same dialog requesting confirmation for deletion. Follow the directions as stated above to delete.

12: Mode Selector:

Select one of three modes:

- Automatic—"point and shoot" mode. All parameters are set automatically.
- Scene—offers choice of 12 scenes plus assisted settings. The settings are automatically optimized for selected subject type.
- Movie—can shoot movies with recorded sound.

Note!

It is strongly recommended that you familiarize yourself with all the controls topside before using these controls while diving.

General Camera Description:

Nikon has expanded its 'Life' series of digital cameras with the arrival of the Coolpix L2, L3 and L4. The Nikon L2 has 6 megapixels, the L3 has 5.1 megapixels and the L4 has 4 megapixels.

All three latest L series models also feature a bright, easy-to-view 2.0-inch LCD that's now even easier to operate with new icons and function selections.

A range of unique Nikon functions enables the photographer to actually improve images in-camera. Available in playback mode, the D-Lighting function selects and creates a copy of images with excessive backlight or insufficient flash illumination, adding light and detail wherever needed while keeping other areas as they were. This can be a beneficial feature when shooting underwater.

The L-series cameras all have 15 scene modes, including 4 that have framing aids for beginners. All of the cameras include Nikon's face-priority technology that searches for faces and automatically focuses on them. The Nikon Coolpix L2 and L3 have movie modes that record 640 x 480, 320 x 240 and 160 x 120 pixels with sound. The L4 can also record at those image sizes, but does so without audio. With high resolution and the outstanding quality of other Nikon features, such as optical performance, you will be able to produce high quality images of the thrilling outdoor activities in which you participate. These cameras were selected as the basis for the housing design due to the combination of image quality and consumer value. For specific features of each camera you should reference your camera's instruction manual or obtain product technical information from Nikon or their dealers.

Nikon COOLPIX L2, L3, L4 Feature Highlights

- Unique combination of all-round quality, ease of operation, and elegant styling makes COOLPIX L2, COOLPIX L3, and COOLPIX L4 the compact digital camera of choice for entry-level photographers
- Compact, portable dimensions for COOLPIX L2 and L3 of 91 x 60.5 x 26mm (3.6 x 2.4 x 1.0 in.) (W x H x D); COOLPIX L4: 86.5 x 60.5 x 34.5mm (3.4 x 2.4 x 1.4 in.)
- Light weight for COOLPIX L2 and L3 of approx. 120g (4.2 oz) (without battery and SD memory card); COOLPIX L4: approx. 115g (4.1 oz) (without battery and SD memory card)
- BSS (Best Shot Selector) automatically selects the shot with the sharpest focus from a series of consecutive images
- Blur Warning informs user after shooting if an image is blurred
- Time zone function enables local time to be set regardless of where you are in the world
- Single AF and Continuous AF selectable in Movie mode
- Capture modes: Single, Continuous and Multi-Shot 16 for COOLPIX L2 and L3; Single and Multi-Shot 16 for the L4
- Built-in flash: features settings for Auto, Auto with red-eye reduction (In-Camera Red-Eye Fix), Off, Fill Flash and Slow sync.
- Noise reduction provides more attractive results in low-light conditions
- Digital zoom of up to 4x
- Choice of White Balance: Auto with TTL control, 6-mode manual (Daylight, Incandescent, Fluorescent, Cloudy, Flash and White Bal. Preset)
- USB connectivity allows quick and easy data transfer to computers and other peripherals

● Using the Fantasea FL-3 and FL-4 housing:

Opening The Housing:

1. Observe that the locking mechanism has 2 recessed spring tabs. Place the lower corner of the housing against your stomach and with 2 fingers, press these tabs together while your other hand frees the rounded housing latch by gently pulling upwards.
2. Next, release the flanged locking mechanism from the other half of the housing and the housings will part open.

Inserting Camera:

Since the **Fantasea's FL-3 and FL-4** was specifically designed for the Coolpix L2,3 and L4 digital cameras, insertion is a simple matter of placing the camera in the housing.

1. Make sure the camera lens is centered in the rounded port area and that the lens does not distort the round black rubber seat. The housing is designed to have the camera fit in place perfectly, but if you are not careful, it is possible to put it in at an improper angle and hence it will be impossible to get a good seal or easy closure of the housing.
2. *After camera insertion, be sure that the extended camera lens does not catch or bend the black rubber seat on the inside of the lens port. It is vital that the lens does not disturb this rubber seat.*

 Notes:	<ol style="list-style-type: none">1. It is recommended to make some camera settings prior to inserting into the housing. Please refer to the Coolpix owner's manual for menu options and personal preferences to choose from.2. Take a few test shots: it is recommended to turn the camera "on" and program to "Flash Always" mode before inserting into housing and then take test shots to make sure all systems are working.
---	---

Underwater photographers will probably want to set the flash mode to the flash always setting to insure they always have a flash with every exposure. It is also wise to set the focus mode to allow the lens to focus in the macro range for capturing great images of the tiny and exotic subjects that you can find underwater.

Checking the Gasket:

Prior to each closure of the housing the gasket seal should be visually inspected. If there is any debris present, including dirt, sand, dust, hair, grease or other matter, it must be cleaned to insure a proper watertight seal. Cleaning the gasket is a simple matter of wiping it with a damp, soft cloth to remove the foreign matter. Be careful the cloth you use does not leave any of its own material behind as this can also affect the effectiveness of the gasket. It is not necessary to remove the gasket for cleaning unless visual inspection determines that there is foreign matter underneath the gasket as well. If this occurs, be sure the surface of the housing is also clean and wiped free of any debris.

Gasket Info:

Since the gasket on the Fantasea FL-3 and FL-4 are face-to-face/compression sealed, and is not subject to friction as it is closed, there is no need to lubricate it. Grease or any other form of lubrication does not help seal the housing. It only reduces friction, which is commonly present if the housing has an O-ring seal. Lubricating the gasket before use could cause it to slip out of its groove, and not form a proper seal: therefore no silicon or other lubricants should be used.

The gasket should also be checked visually for any cracks or perforations. If any part of the gasket shows signs of wear or damage, it is imperative that it be changed before going into the water.

If the gasket is removed from the channel groove it sits in, be sure to get it completely back into place so it is properly seated. Starting at one corner, press the gasket with your finger and feel it seat into its channel groove. Then continue this procedure continuously in one direction, round its perimeter, until the entire gasket has been pressed flat into place. Go over it a second time to be sure it is properly in place. Then you are ready to clean it, give it a final visual inspection, and close the housing.

Closing the Housing:

1. Bring the two halves of the housing together with one hand [squeezing your thumb on one side and your other fingers on the other until the two halves touch and hold securely in that position. With the other hand, attach the flange to the body of the camera and gently lower the rounded latch until it snaps into place.
2. Never force the housing closed; if it does not close easily, please check to make sure that the camera is well seated and that the lens is sitting properly in the port area and not distorting the rubber seat.
3. It is most important to check to make sure the rectangular rubber gasket [blue or black] is seated correctly in its niche [not raised at any point and sitting in its groove] and that there is no sand, dirt or any other foreign object on its surface. Do not use any lubricant whatsoever on this gasket—especially silicon grease which will distort it. Make sure that the black wrist lanyard is not jammed into the housing during the closing procedure.
4. Always take the first dive without your camera in the housing just to make sure there is no leakage from damage to the housing. During the dive—especially at the beginning of descent—take special care to look at the housing to make sure no bubbles are escaping from it and that no water is entering. Generally, if there is a problem with the seal, you will discover it in the first seconds of the dive.

Viewing the Subject:

The L2, L3 and L4 cameras do not have the standard eyepiece but underwater photographers and outdoor photographers will appreciate the large LCD viewing monitor for composing photographs. The LCD monitor will allow you to see your subject in sharp focus and framed properly. Hold the camera housing in your outstretched arm at a position that is both comfortable and also allows you to easily see the LCD monitor, for best compositional options.

Taking the Picture:

Once you have composed your scene or subject in the LCD monitor, depress the shutter release button to take the picture. A half depress will activate the live viewing ability of the LCD and allow the camera to focus, once in focus and ready to shoot a green light will appear on the LCD monitor and the camera is ready to take the picture. Press down the shutter all the way to complete image capture. You may notice a pre-flash and slight delay in the shutter release. This is to allow the camera to make its final focus and exposure calculations before taking the picture. With a little practice, you will become used to this and taking pictures of moving subjects will become easier and natural.

Choosing Image Files:

There are several image file options to choose from that offer different resolution and file sizes. This determination must be made prior to camera insertion from Menu options. Please refer to the Coolpix instruction manual for details on setting these preferences.

Battery life:

AA-Size Battery Compatibility

One of the most widely available battery sizes in the world - in alkaline, lithium, rechargeable or other forms - AA compatibility allows near-ubiquitous use anywhere in the world. The power to shoot approximately 180 shots for the COOLPIX L2, 200 shots for the COOLPIX L3, and 250 shots for the COOLPIX L4 when using alkaline batteries greatly augments their compact convenience.

There are certain things that users can control to help with battery life. The most important is to set the camera to turn the LCD off after a short time, during periods of non-use. It can then be automatically turned back on if you depress the shutter release control half way. Please refer to the Coolpix instruction manual for details on how to make this adjustment setting. It is always wise to have backup batteries in case you do run out of power. The supplied battery can be recharged many times and offer an economical and environmentally friendly power source.

Using The Flash:

The Coolpix has a built-in flash, which will illuminate nearby underwater subjects. For subjects that are farther away, an accessory slave flash is recommended. (See Below.) A built-in flash diffuser is supplied which will help achieve a wider and softer light source thereby providing more coverage and less likelihood of *backscatter* (the unattractive snowstorm affect of the flash reflecting off the suspended particles in the water). Further reduction of *backscatter* can be achieved by using an accessory off-camera slave flash. This will be discussed in more detail.

The need for artificial light to maximize color reproduction is necessary in nearly all pictures. Therefore it is strongly recommended that you set the flash mode to *Flash Always*. This will insure the flash fires on every exposure regardless of the ambient light conditions. (Please refer to the camera's instruction manual for more details.) Outdoor photographers do not have this same concern. There is no backscatter to be concerned with, and due to the ability of the flash to travel farther and more effectively in air as compared to in water, there is normally not a need for an accessory flash to provide proper illumination for most subjects.

Accessory Slave flash:

If you should use the Coolpix built-in flash as the master, you can trigger a second *slave* flash to provide more artificial light when needed. To do this, you must use an accessory flash that has a *slave* feature built in. The flash from the Coolpix must be aimed or bounced toward the accessory flash's *slave* sensor, or other fiber optic sensor. This will trigger the slave to fire in sync with the master flash. When using an accessory slave flash with fiber optic cable, it is recommended to black out the internal camera flash. The internal flash is located near the camera lens and can contribute to backscatter by illuminating floating particles close to the lens port.. If the sensor of the fiber optic cable is attached to the outside of the housing directly above the internal flash and taped over with black tape—it will block out the light from the internal flash but transmit the light pulse to the external slave flash.

Note!

Be sure to use a slave flash that has the ability to ignore the built-in pre-flash in digital cameras, and synchronizes with the shutter release.

Lens Accessories:

The Fantasea FL-3 and FL-4 are designed to work with some of the wide-angle and macro adapters that are currently on the market. Fantasea Line offers a macro/wide angle converter lens adapter for this purpose. The converter lens can be used with one of its two elements for super macro images, or with both of its elements for great wide angle images. Red Filters which go over the lens port or on the converter lens itself are also available. For more information on these items, see your local photo dealer or visit our website at www.fantasea.com

Fantasea Coolpix Accessory Systems and Sets:

Fantasea Offers a variety of Coolpix (and other housings) sets made up of quality accessory products which serve to enhance and improve your underwater images. Products like external flash systems, flexible arms, trays, filters, wide angle and macro lenses, fiber optic cables and more. Below you can see one sample system. For more information please refer to our website or to the Fantasea Dealer where you purchased your housing.

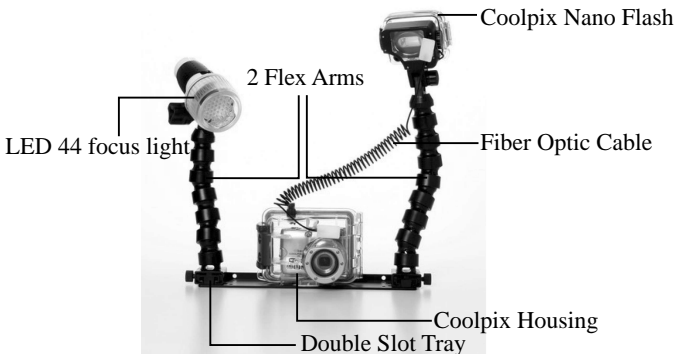

Coolpix Accessory System

Shooting Techniques:

Exposure Modes: (Pre-set before camera insertion)

There are several exposure modes [15 different Scene modes] for photographers to choose from, depending on the situation. Underwater it is recommended that you shoot in the Auto mode on the camera in which ambient light and artificial light will be automatically controlled by the camera according to the lighting conditions. You can also select different light meters to use, based on the situation and your personal preferences. Additionally, you can choose the Auto White Balance setting for color temperature control, or experiment with some of the other modes to see which will work best underwater. These settings do not have to be made ahead of any dive, as they can be accessed through the housing controls while underwater.

Please reference the Coolpix instruction manual for details on how to set these camera options, and under what conditions the different choices would be used.

Zoom Control:

Zoom in for telephoto photos and larger subject size. Zoom out for wide-angle scenes. It is generally not recommended to use the zoom underwater as it is preferable to get physically closer to your subject. The digital zoom has no value at all.

Macro Focus:

For capturing the tiny and exotic subjects that require close focus. Macro focus is possible when the lens is in the wide-angle position.

Quick Review:

Immediate review of most recent image is available that will confirm that you captured the shot you want. However, if you want to scroll through your images, or delete images from the memory card, this should be done when you are topside and the camera is out of the housing.

Camera Standby Mode:

You can access the camera's menu to choose how long a period of inactivity before the camera goes into *standby mode*. Options are 30 seconds, one minute, five minutes, and 30 minutes. This feature allows you to conserve battery power by placing the LCD monitor on standby [sleep mode]. It is recommended that this option is set for 30 seconds for the following reasons: to conserve battery power and longer periods of time will cause a warming of the LCD screen. This will cause heating of housing and this can produce condensation and fogging of the lens port. If this occurs and the condensation appears on the lens port then it will have a negative impact on the quality of the images taken.

When you want to resume shooting, pressing any button will reactivate the camera. However, if after the camera goes into standby, a further period of three minutes goes by without any activity, the camera will turn off [deep sleep mode]. You can turn it back on by pressing and **holding** the triangular icon button--Review/Restore [Playback] for about five seconds. The Welcome to Nikon Coolpix screen will appear then it will display last image taken. One additional press of the Review button will then return the camera to active shooting mode.

Care & Maintenance:

The Fantasea FL-3 and FL-4 housings require only a minimum amount of care for reliable performance. The following are tips that will enable you to get the best results.

1. Always rinse your housing with a strong stream of fresh water and if possible soak your housing in fresh water tub or rinse tank for about 20 minutes after every dive in order to dissolve the salt water crystals from around the controls and openings of the housing. Manipulate each of the movable controls to assist the removal of salt particles from these tight areas.
2. Allow the housing to dry thoroughly before packing away for the day or for the trip home. You may use a soft towel or cloth to dry the housing. Be sure there is no grease or other debris on the towel.

3. Visually check the condition of the gasket before every dive. If it is dirty, clean it with fresh water and dry it with a soft cloth as described above. If it is damaged in any way, such as cut or perforated, replace it immediately.
4. Do not use grease or any other type of lubricant on the gasket when closing the housing. It does not increase the ability of the gasket to make a proper seal.
5. Be careful not to get greasy fingerprints or dirt on the lens port. This will affect the image quality. Wipe any dirt or grease off with fresh water and a soft cloth.
6. Do not drop the housing on hard surfaces. It is not a shock absorber, and could crack, affecting its watertight integrity. It could also cause damage to the camera inside.
7. Travel with the housing protected in a padded case. It is best to remove the camera from inside the housing when traveling and provide it with its own protective case, or compartment.
8. Never dive with the **Fantasea** FL-3 and FL-4 housing to a depth greater than 130 ft/40 meters.
9. It is recommended to have annual maintenance of all Fantasea housings. This includes visual inspection and possible changing of all seals / gaskets / o-rings. It is recommended to use an authorized Fantasea Service Center for this purpose. Please contact Fantasea Line by email: service@fantasea.com or visit the Fantasea Customer Service section at the end of this manual or on the Fantasea web site www.fantasea.com.
10. It is recommended that you select the shortest time option on the menu, for placing the camera into standby during periods of inactivity. This will conserve battery power and reduce the heat given off by the LCD screen, which can contribute to condensation inside the housing and fogging.
11. It is strongly recommended to take the first dive without the camera inside the housing. You should check that the water tight seal has not been affected during transport and long periods of storage.

12. It is likewise recommended to visually monitor the housing during every descent, especially for the first 10 meters/33 ft. If water is observed entering the housing or bubbles escaping from it, the housing should be rotated to a *port down position* and held that way as you return to the surface immediately and get out of the water.

Flood Insurance:

Every **Fantasea** housing includes a one-year flood insurance policy. Supplied by the Divers Equipment Protection Program (DEPP), this insurance policy acts as additional protection to the warranty and is good for one year. If your **Fantasea** housing experiences water leakage in this period of time you will be compensated for the loss of the camera. Only a small shipping charge will apply. All insurance policies should be activated at the time of purchase. All owners must complete the on-line product registration form by going to www.fantasea.com and go to the Customer Support tab and choose Product Registration; you will be taken to this page--http://www.fantasea.com/product_registration.asp where you can complete the form and register your housing purchase. Failure to register the product within 30 days of purchase will result in a shorter period of insurance coverage for your housing and may in the end cancel the flood insurance coverage all together. Also, you must keep the original Bill of Sale in the event of the need to make a claim:

For DEPP flood insurance claims please submit your claim to <http://www.fantasea.com/claims.asp>