



Owner's Manual

This manual is for the installation, operation, and maintenance of the

ScaleGard™ PLUS 2 Water Treatment Systems

STM150

TSR150

Installer please leave manual with end user.

SAFETY INFORMATION

Read, understand, and follow all safety information contained in these instructions prior to installation and use of the CUNO Foodservice STM150/TSR150 ScaleGard™ PLUS 2 Water Treatment Systems. Retain these instructions for future reference.

Intended use:

The CUNO Foodservice STM150/TSR150 ScaleGard PLUS 2 water treatment systems are intended for use in filtering and scale reductions for water used in coffee and espresso equipment, steam kettles and tables, combis, electric and gas steamers, misters or other similar equipment, and have not been evaluated for other uses. The system is typically installed near where treated water is desired, and must be installed as specified in the installation instructions.

EXPLANATION OF SIGNAL WORD CONSEQUENCES	
 WARNING	Indicates a potentially hazardous situation, which, if not avoided, could result in death or serious injury and/or property damage.
CAUTION	Indicates a potentially hazardous situation, which, if not avoided, may result in property damage.

 WARNING
<p>To reduce the risk associated with ingestion of contaminants due to use with water that is microbiologically unsafe or of unknown quality:</p> <ul style="list-style-type: none"> • Do not use with water that is microbiologically unsafe or of unknown quality without adequate disinfection before or after the system.
<p>To reduce the risk associated with hazardous voltage due to damage of the transformer/power supply:</p> <ul style="list-style-type: none"> • Do not use the ScaleGard system if the transformer/power supply is damaged — contact qualified service personnel for repair.
<p>To reduce the risk associated with hazardous voltage due to an installer drilling through existing electric wiring or water pipes in the area of installation:</p> <ul style="list-style-type: none"> • Do not install near electric wiring or piping which may be in path of a drilling tool when selecting the position to mount the filter bracket.
<p>To reduce the risk associated with back strain due to the heavy weight of the system:</p> <ul style="list-style-type: none"> • Follow safe lifting procedures.

CAUTION
<p>To reduce the risk associated with property damage due to water leakage:</p> <ul style="list-style-type: none"> • Read and follow Use Instructions before installation and use of this system. • Install on cold water lines only. • Installation must comply with existing state or local plumbing codes; • Do not use a torch or other high temperature sources near filter system or cartridges; • Protect from freezing. Drain filter when room temperature drops below 40°F (4.4°C); • Do not install on systems where line pressures above 65 psi (448 kPa) may occur. Line water pressure in excess of 65 psi will require installation of a pressure regulator prior to the unit; • Shut off inlet water supply and depressurize system as shown in manual when changing cartridges or servicing; • The filter must be installed with the inlet and outlet ports as labeled. Make sure not to reverse connections; • Do not install near water pipes which will be in path of a drilling tool when selecting the position to mount the bracket; • Mount the system in such a position as to prevent it from being struck by other items used in the area of installation.

IMPORTANT NOTES
<ul style="list-style-type: none"> • Allow minimum of 3" (7.62 cm) clear space under [the assembly] to facilitate cartridge changes; • All components should be accessible and have at least 6" (15 cm) of clearance on all sides of the system to facilitate servicing.

Contents

Installation Requirements

Space Requirements	3
Feedwater Parameters	3
Electrical Requirements	3
Water Production Chart	3
Installation Schematic	4
Operating Parameters	4
Additional Plumbing Connections	4

Installation Procedure

Positioning Equipment	5
Wall Mounting the Filter System	5
Feedwater Connections	5
Drain Connections	6
Automatic Bypass Installation	6
Storage Tank Installation	6
Point of Use Connections	6

Start-Up Procedure 7

Routine Maintenance

De-pressurization Procedure	7
Sediment Prefilter Cartridge Replacement	7
Chlorine Filter Replacement	7
TDS Reduction Filter Replacement	8
Hardness Filter Replacement	8
Ion Media Filter Replacement	8
Restarting and Purging the RO System	8
'Push-In' Tubing Connector	9

Electrical Wiring Diagram 9

Installation Components 9

System Parts List 10

Warranty 11

Important: Installation Requirements

CAUTION

To reduce the risk associated with property damage due to water leakage:

- Installation **must** comply with existing state or local plumbing codes;
- **Read and follow** Use Instructions before installation and use of this system.

Space Requirement

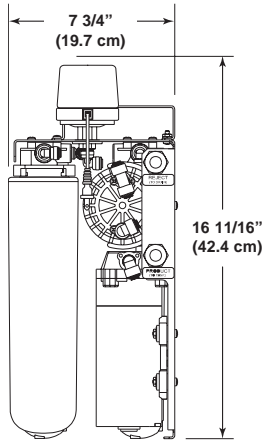
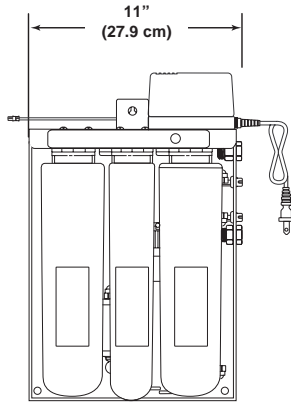

Congratulations on your purchase of the CUNO Foodservice ScaleGard™ PLUS 2 water treatment system. The ScaleGard PLUS 2 systems utilize some of the world's most advanced scale and corrosion control technologies in a compact, highly efficient package.

The ScaleGard PLUS 2 system is designed for food service equipment with low water draw such as steam kettles and tables, combis, electric and gas steamers, misters or other applications, where water consumption does not exceed 6 gph (22.7 lph) continuous. See estimated water production chart below.

The ScaleGard PLUS 2 STM150 is recommended where a minimal TDS level is required for proper equipment operation. The ScaleGard PLUS 2 TSR150 is recommended for applications where zero hardness is required such as proofing ovens, flash steamers, injection steamers and misters.

Before beginning the installation, take a few minutes to familiarize yourself with the system by reviewing the entire installation, operating and maintenance manual. It is also important to review the criteria below to make sure that the requirements have been or will be met when the installation is complete. Be sure to confirm that the feedwater falls within the limits shown below. If you're not sure if this has been done, check with your distributor before installing the system. **This is important because failures caused by water related problems are not covered under the system warranty.**

Installation must comply with state and local plumbing requirements.

Feedwater Parameters:

- Feed TDS Up to 2000 ppm (mg/L)
- Hardness* < 10 grains (171 mg/L)
- Iron (Fe) < 0.1 mg/L
- Hydrogen Sulfide none allowable
- Feed pH 4-11
- Free chlorine < 2 mg/L
- Manganese(Mn) < 0.05 mg/L
- Turbidity < 5 NTU

* **Note:** For waters over 10 grain hard, a CUNO water softener is recommended for pretreatment. Consult CUNO technical services for correct sizing.

Electrical Requirements:

Confirm that transformer is compatible with available electrical power supply.

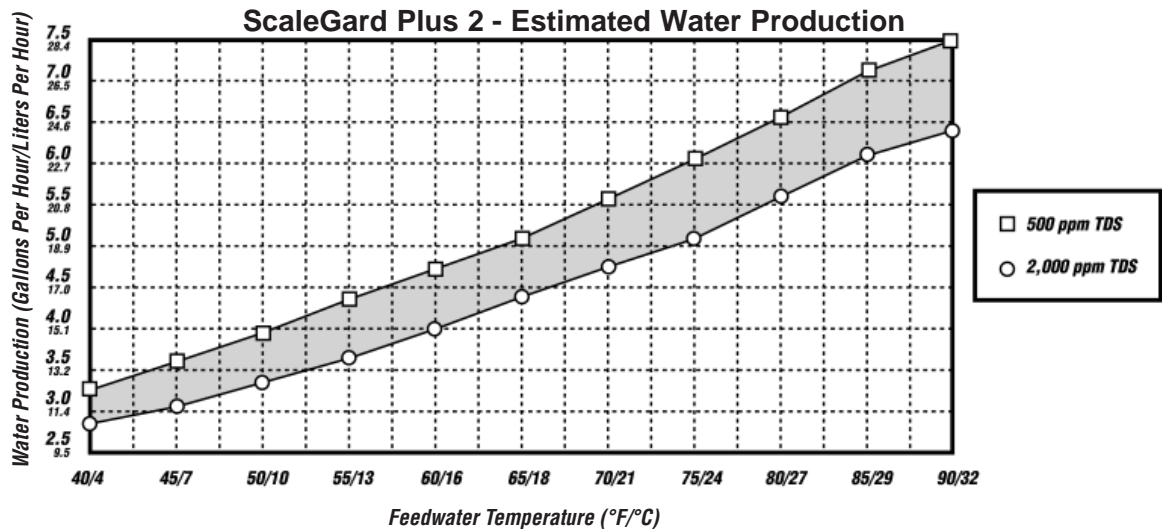

ScaleGard™ PLUS 2 Installation Schematic

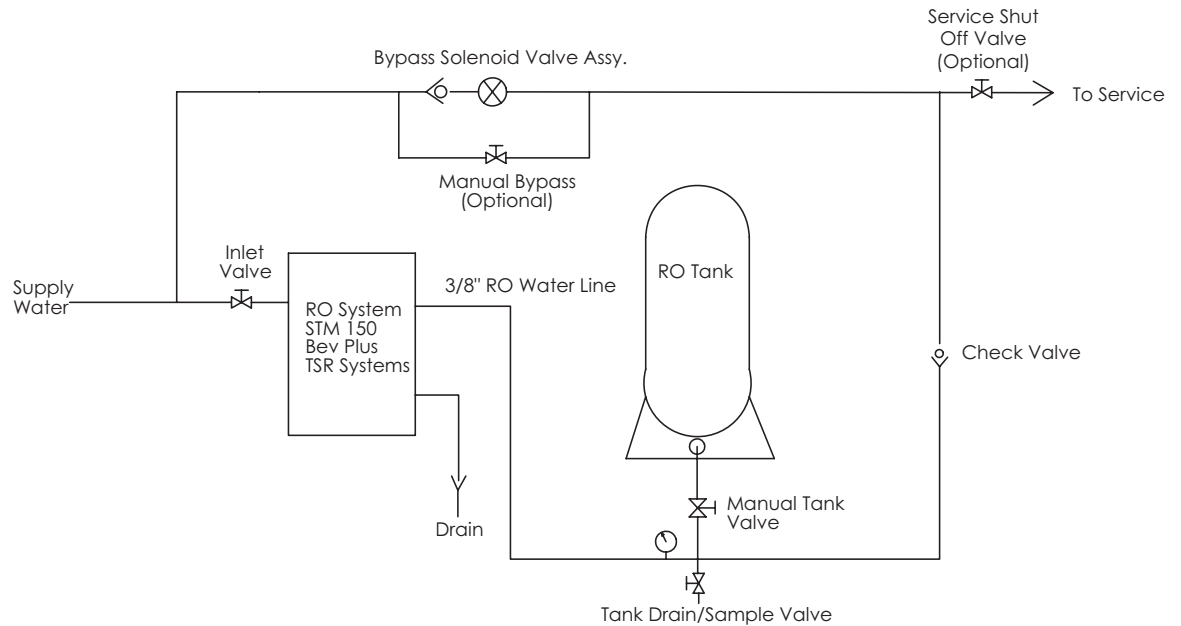

Additional Plumbing Connections (not supplied)

- Manual Bypass:**
 A manual bypass loop is recommended to facilitate proper service of the filter system.
- Drain Line:**
 A drain line is recommended to depressurize the system during cartridge changeout, for sanitizing the system, and for draining the tank. **Note:** 10, 20, and 40 gallon (38, 76, 151 liter) tanks are capable of draining water in excess of 13 gpm (49 lpm). Drain connection must be sized accordingly.
- Pressure Gauge:**
 A pressure gauge in the product water line is recommended to determine the system's performance and when the system is de-pressurized.

If your water analysis indicates that any of these parameters are not in range, additional pretreatment or higher frequency of maintenance may be required. Contact your distributor for assistance. The presence of silica or flocculants (e.g. alum or cationic polymers) in the feedwater can cause membrane fouling and may require special chemical pretreatment or periodic membrane cleaning.

Operating Parameters:

Typical TDS Cartridge Rejection..... >95%
 Feed Temperature..... 40-100°F (4-38°C)
 Feed Pressure..... 20-65 psi (138-448 kPa)*
 Production..... Chart on page 3 shows output in gallons per hour at varying water temperatures. Actual output may vary according to feedwater conditions and membrane variations.

Note: For water temperature below 50°F (10°C) water can be preheated to improve production rate.

CAUTION

***To reduce the risk associated with property damage due to water leakage:**

- Do not** install on systems where line pressures above 65 psi (448 kPa) may occur. Line water pressure in excess of 65 psi will require installation of a pressure regulator prior to the unit.

Installation Procedure

CAUTION

To reduce the risk associated with property damage due to water leakage:

- Installation **must** comply with existing state or local plumbing codes;
- **Read and follow** Use Instructions before installation and use of this system.

Positioning Equipment

Prior to installing the ScaleGard™ PLUS 2 system, review the installation schematic (page 4) and carefully plan the installation location for all system components. Obtain all additional hardware for plumbing connections. This will help provide proper positioning and improve serviceability during routine maintenance.

1. Position the storage tank in desired location. (See storage tank installation procedure, page 6.)
2. The ScaleGard PLUS 2 system should be installed within 15 ft (4.6 m) of the storage tank.
3. The ScaleGard PLUS 2 system must be installed within 6 ft (1.8 m) of an electrical outlet. The bypass solenoid valve should be installed within 6 ft. (1.8 m) of the storage tank.
4. All components should be accessible and have at least 6 inches (15 cm) of clearance on all sides of ScaleGard PLUS 2 system to facilitate servicing.
5. Access to feedwater and drain connection are also required.

Wall Mounting the Filter System

The filter system weighs approximately 30 lbs. (13.6 kg) and must be mounted securely to a rigid surface. There are two additional mounting holes on both sides of the booster pump at the bottom of the bracket if needed. System must be installed vertically.

1. Determine the desired mounting location and using the supplied template, mark mounting hole locations.
2. Install the three mounting screws in the marked locations, leaving about an 1/8" (3.2 mm) from the wall.
3. Remove the cartridges from the filter system by turning to the left 1/4 turn and pull down to remove.
4. Lift the filter system and align the keyhole slots over the mounting screws. Tighten the screws, securing the filter system to the wall. **Note: You may have to slide the permeate pump to the left to fully expose the right mounting hole.**
5. Install the cartridges. **Note: Mate the head icon letter with the cartridge icon letter (S, C, M, T or H). The TDS filter (M) has a John Guest® fitting for reject water. Attach reject tubing to the fitting (as shown in drawing below).**
6. Mount the transformer to the bracket with screws provided to the top right side of the bracket.

Feedwater Connection

The feedwater supply line is 3/8" O.D. tubing and should not exceed 20 ft (6.1 m) from the main feedwater connection to the filter system. For longer distances, 1/2" pipe or larger should be brought to within 20 ft (6.1 m) of the system. **Important:** Connect to an adequate water supply having a minimum 20 psi (138 kPa) and maximum 65 psi (448 kPa) pressure *at the inlet of the filter system.*

CAUTION

To reduce the risk associated with property damage due to water leakage:

- **Do not** install on systems where line pressures above 65 psi (448 kPa) may occur. Line water pressure in excess of 65 psi will require installation of a pressure regulator prior to the unit.

1. Connect a shut-off valve to main water line. **Under no circumstances should a needle valve or self piercing valve be used.**
2. Run a 3/8" O.D. line from the feedwater connection at the main water line to the water inlet on the filter system. Inlet connection is a 3/8" John Guest fitting.

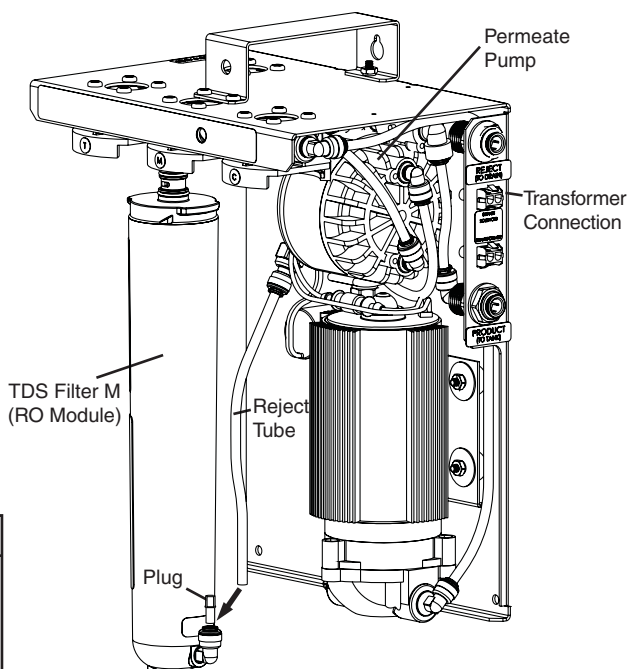

IMPORTANT: Remove white plug from module and insert black tube as shown. Insert RO module into filter head and rotate 1/4 turn until it stops. The label should face the front.

The water pressure in the tank will increase as the tank fills with water. When the pressure in the tank reaches approximately 80 psi (552 kPa) the filter system shuts off. When water is drawn from the tank and the pressure drops to approximately 60 psi (414 kPa), the filter system will automatically turn on.

If the tank pressure drops to 40 psi (276 kPa) the auto-bypass solenoid valve will open allowing unfiltered water to flow to service until tank pressure reaches approximately 60 psi (414 kPa). When the filter system is in auto-bypass the red light on the front of the bracket will come on.

NOTE: TSR150-2/2A/2B Bypass at 20psi (138 kPa) to 40 psi (276 kPa).

IMPORTANT!

The use of metallic piping materials for high quality water is not recommended because the water is aggressive due to low TDS and pH. Plastic tubing and pipe are most suitable. Solvent bonded plastic pipe should be assembled carefully to avoid excessive glue inside the pipe. Piping of any type should be flushed thoroughly before use. Be sure piping conforms to local plumbing codes.

Drain Connection

Important: An approved air gap should exist between the filter system drain lines and the drain opening to meet local plumbing codes.

1. Run a minimum 3/8" O.D. tube from the reject port to the drain.
2. The 3/8" O.D. reject tubing line may be run up to 10 ft (3 m) from the filter system to the drain. Care must be taken not to crimp or block the reject tubing line.

Automatic Bypass Valve

The auto-bypass valve has 3/8" MNPT inlet and outlet ports and a 6' (183 cm) power cord that plugs into the filter system. This auto-bypass valve should be installed between the incoming unfiltered water line to the filter system and the water line to service after check valve. (Refer to page 4.)

Storage Tank Installation

Note: Storage tanks are purchased separately. Consult the CUNO® Foodservice Price List for applicable sizes and part numbers.

1. Follow installation instructions provided with tank.
2. Check the air pressure in the tank at the valve in the top of the tank. With the tank empty, the pressure should be 20 psi (137.9 kPa). Adjust the air pressure as required.
3. Place the tank in the desired location. It should be placed in an area where it will not be bumped or jarred.
4. Connect fitting and minimum 3/8" O.D. tubing to product port of the unit.
5. Run tubing from the other side of the TEE to the check valve and on to point of use connection and bypass line. Refer to Installation Schematic on page 4.
6. Open the ball valve on the tank by turning the handle until it is parallel with the body of the valve.

Storage Tank	Diameter	Height	Pipe Connection
2.5 gal. (9.5 lit.)	9 1/16" (23 cm)	14 1/8" (35.9 cm)	1/4" (0.6 cm)
5 gal. (19 lit.)	15 3/8" (39.1 cm)	17 3/8" (44.1 cm)	3/4" (1.9 cm)
10 gal. (38 lit.)	16" (40.6 cm)	32 1/2" (82.6 cm)	1" (2.5 cm)
20 gal. (76 lit.)	16" (40.6 cm)	57 1/2" (146.1 cm)	1" (2.5 cm)
40 gal. (151 lit.)	24" (61 cm)	56 1/2" (143.5 cm)	1 1/4" (3.2 cm)

Point-of-Use Connections

Distance from Storage Tank to Point of Use	Recommended Minimum Tubing Size	Recommended Minimum Plastic Pipe Size
up to 5 ft (0-1.5 m)	1/2" O.D. (1.3 cm)	3/8" (1 cm) Schedule 40 PVC
5-20 ft (1.5-6.1 m)	3/4" O.D. (1.9 cm)	1/2" (1.3 cm) Schedule 40 PVC
20-40 ft. (6.1-12.2 m)	N/R	1/2" (1.3 cm) Schedule 40 PVC
40-60 ft. (12.2-18.3 m)	N/R	3/4" (1.9 cm) Schedule 40 PVC

Note: The above table is appropriate for point of use applications that require flow rates up to 5 gpm (18.9 lpm).

Select the tubing or pipe size that will help provide adequate flow and pressure to the point of use (i.e. Longer runs require larger tubing).

The type of tubing or pipe used must conform to local plumbing codes. Tubing or pipe used for drinking water applications must be NSF listed or made of FDA compliant materials.

Start-Up Procedure

1. Check air pressure in the storage tank, Refer to Storage Tank Installation. (page 6)
2. Close all water valves (5) in the system. (page 4)
3. Open water supply valve at the connection to the main water feed and the inlet water valve at the unit. If manual bypass is installed it should be in the filter position.
4. Plug in transformer.
5. Plug bypass solenoid into the filter system.
6. Open the drain/sample valve. This will purge the air from the system. When you see a steady stream of water close the drain/sample valve.
7. Open the ball valve on the storage tank.
8. Inspect all connections, fittings in the system for leaks, repair as necessary.
9. Allow storage tank to fill with RO water. NOTE: see chart for required times to fill storage tanks.
10. Open valve in water line to service and flush feed lines to each point of use.
11. System is now ready to use.

Tank Capacity	Time Required To Fill Tank
2.5 gal. (9.5 lit.)	0.4 - 0.5 hour
5 gal. (19 lit.)	0.9 - 1.1 hours
10 gal. (38 lit.)	1.8 - 2.1 hours
20 gal. (76 lit.)	3.6 - 4.2 hours
40 gal. (151 lit.)	7.2 - 8.4 hours

@ 70°F (21°C) Water Temperature

Routine Maintenance

CAUTION

To reduce the risk associated with property damage due to water leakage:

- Installation **must** comply with existing state or local plumbing codes;
- **Read and follow** Use Instructions before installation and use of this system.

De-pressurization Procedure

1. Turn off the inlet water valve.
2. Close the tank ball valve.
3. Open the drain line valve.
4. Wait for 30 seconds, then unplug the transformer. System is now de-pressurized.
Caution: Tank will still be under pressure.

Sediment Filter (S)

Replacement Procedure [6-12 months]

1. De-pressurize the system as instructed above.
2. Locate the sediment filter. To remove the sediment filter, turn to the left 1/4 turn. Pull down to remove and discard it.
3. Insert the new filter by aligning the tabs with the filter head. Push up to insert and turn to the right 1/4 turn.

Chlorine Reduction Filter (C)

Replacement Procedure [6-12 months]

1. De-pressurize the system as instructed above.
2. Locate the chlorine reduction filter. To remove the chlorine reduction filter, turn to the left 1/4 turn. Pull down to remove and discard it.
3. Insert the new filter by aligning the tabs with the filter head. Push up to insert and turn to the right 1/4 turn.

TDS Reduction Filter (M) Replacement Procedure [annually]

1. De-pressurize the system as instructed above.
2. Locate the TDS reduction filter. To remove the TDS reduction filter, turn to the left 1/4 turn. Pull down to remove.
3. Disconnect reject tubing by pushing in the white collet on plastic fitting to release the tubing (see page 9). Discard the used cartridge.
4. Remove the plug from the plastic fitting on the new cartridge and connect the reject tubing.
5. Insert the new filter by aligning the tabs with the filter head. Push up to insert and turn to the right 1/4 turn.
**Note: The first full tank of water filtered after the filter is replaced should be discarded.
See start-up procedure, page 7.**

Hardness Reduction Filter (H) (ScaleGard™ PLUS 2 TSR150) Replacement Procedure [6-12 months]

1. De-pressurize the system as instructed above.
2. Locate the hardness reduction filter. To remove the hardness reduction filter, turn to the left 1/4 turn. Pull down to remove and discard it.
3. Insert the new filter by aligning the tabs with the filter head. Push up to insert and turn to the right 1/4 turn.
**Note: The first full tank of water filtered after the filter is replaced should be discarded.
See start-up procedure, page 7.**

TDS Adjustment Filter (T) (ScaleGard PLUS 2 STM150) Replacement Procedure [6 months]

1. De-pressurize the system as instructed above.
2. Locate the TDS adjustment filter. To remove the TDS adjustment filter, turn to the left 1/4 turn. Pull down to remove and discard it.
3. Insert the new filter by aligning the tabs with the filter head. Push up to insert and turn to the right 1/4 turn.
**Note: The first full tank of water filtered after the filter is replaced should be discarded.
See start-up procedure, page 7.**

Restarting and Purging the RO System

1. Turn on inlet water valve.
2. Make sure the tank ball valve is closed.
3. Open the drain/sample valve
4. Plug in the transformer and wait for a steady stream of water to come from the drain/sample valve. This will purge the air from the system.
5. Close the drain/sample valve and wait for pump to shut off (this will pressurize system). Check for leaks.
6. Open tank ball valve.
7. Plug in bypass solenoid valve.

'Push-In' Tubing Connector (John Guest® Fitting)

This product is outfitted with user friendly "Push In" connectors. Proper use of the connectors is shown in the diagrams. It is most important that the tubing selected for use with these connectors be of high quality, exact size and roundness, and with no surface nicks or scratches. If it is necessary to cut the tubing, use a plastic tubing cutter or sharp razor knife. Make a clean square cut. Should a leak occur at a 'Push In' connector, the cause is usually defective tubing.

To fix leaks:

- Relieve pressure.
- Release tubing.
- Cut off at least 3/8" (9.5 mm) from end.
- Reattach tubing.
- Confirm connection is leak free.

To Attach Tubing

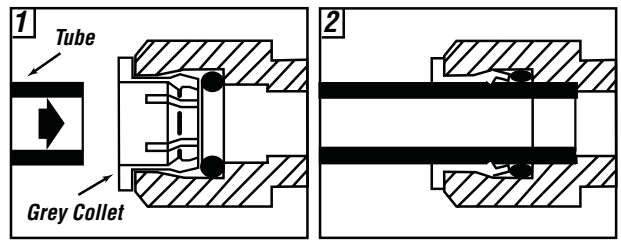

Push tubing straight in as far as it will go. Tubing is secured in.

To Release Tubing

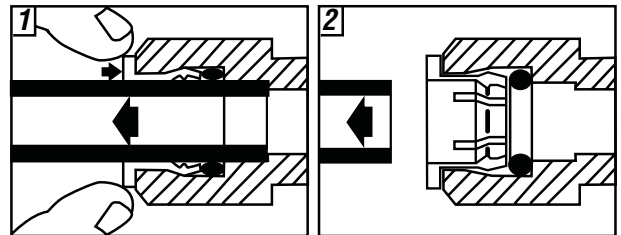

Push in grey collet to release tubing.

Pull tubing straight out.

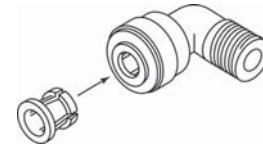

ScaleGard™ PLUS 2 Electrical Wiring Diagram

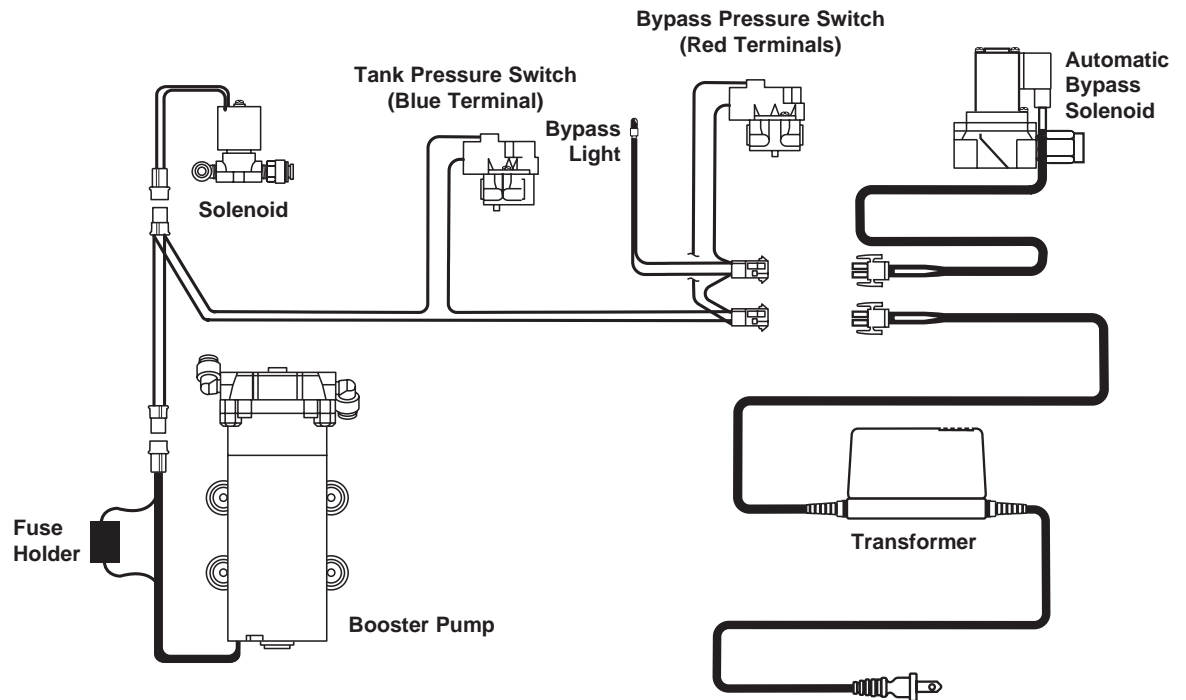

Installation Components for ScaleGard™ PLUS 2 Systems*

- 1 pc of 3/8" Cross
- 1 pc of 3/8" x 1/4" Reducer Bushing
- 6 pcs of 1/2" x 3/8" Male Connector
- 1 pc of 3/8" Female Ball Valve
- 3/8" Nipple
- 1/2" Tubing (optional)
- 1 pc of 1/4" x 3/8" Male Connector
- 1 pc of 1/4" NPT 0-160 pressure gauge
- 1 pc of 3/8" Female Pipe Tee
- 1 pc of 3/8"x1" Reducer Bushing
- 3/8" Tubing
- Cutter or sharp razor knife.

* Not Provided With System

ScaleGard™ PLUS 2 System Part List

Item #	Description	STM150	TSR150-2	TSR150-4
1	Sediment Filter (S)	55997-01	55997-01	55997-01
2	Chlorine Reduction Filter (C)	55995-01	55995-01	55995-01
3	TDS Reduction Filter (M)	55987-07	55987-07	55987-07
4	Ion Media Filter (T)	55998-01	-	-
4	Hardness Reduction Filter (H)	-	55996-01	55996-01
5	Permeate Pump	89-1331202	89-1331202	89-1331202
6	Pump / Fuse Assembly	53-41401	53-41401	53-41401
7	Solenoid Valve	60-1213201	60-1213201	60-1213201
8	Brine Flow Control	53-52001	53-52001	53-52001
9	Bypass Solenoid Valve Assembly (60 Hz)	50-025	50-025	50-025
9	Bypass Solenoid Valve Assembly (50 Hz)	50-026	50-026	50-026
10	Transformer (115V/60 Hz)	25-63031	25-63031	25-63031
10	Transformer (230V/50 Hz)	25-63032	25-63032	25-63032
10	Transformer (100V/50 Hz)	25-63030	25-63030	25-63030
Not Shown	Tank Switch (blue plug)	25-15505	25-15505	25-15505
Not Shown	Bypass Switch (red plug)	25-15503	25-15502	25-15503
Not Shown	Fuse, 2 Amp, 3AGC-250V	25-61225	25-61225	25-61225

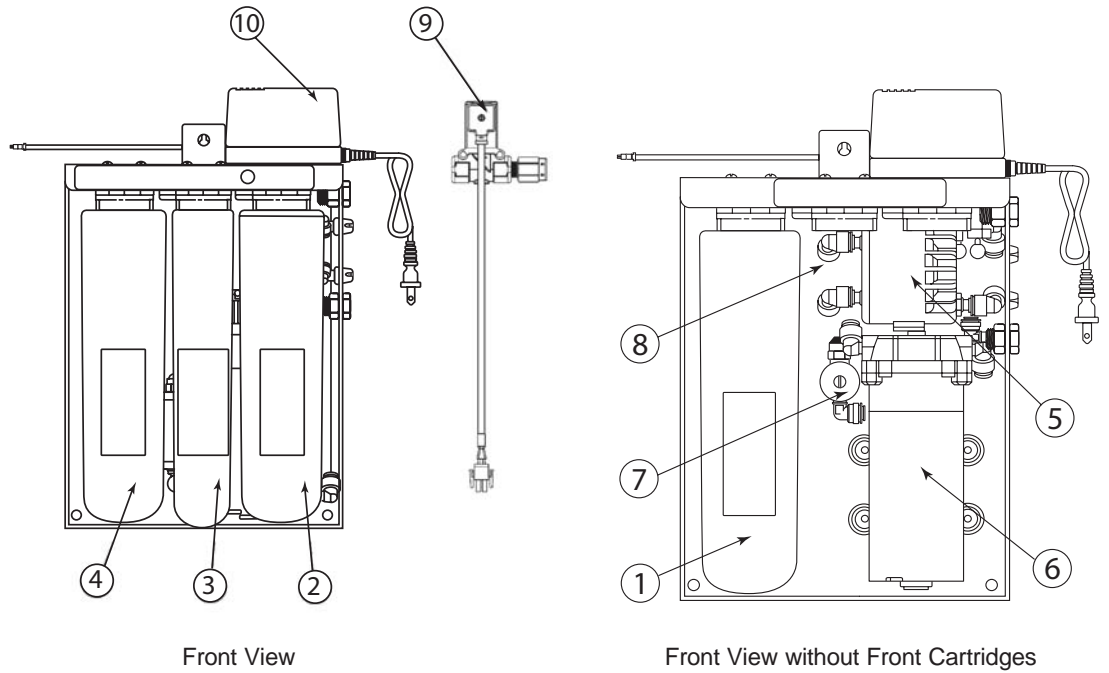

Limited Two Year Warranty

CUNO Incorporated warrants the original purchaser-consumer of its Product that is free of defects in materials and workmanship. Any defect, malfunction, or other failure of the Product to conform to this warranty will be remedied by CUNO in the manner provided below.

This Warranty, together with any warranties implied by law, shall be limited to a duration of two (2) years from the original date of purchase by the consumer.

This Warranty does not apply to defects that result from abuse, misuse, alteration or damage not caused by CUNO.

IMPORTANT: To file a claim under this warranty you must complete and mail the Warranty Registration Card supplied with this product to CUNO at the address below within ten (10) days of original purchase date.

THIS WARRANTY DOES NOT COVER, AND IS INTENDED TO EXCLUDE ANY LIABILITY ON THE PART OF CUNO, WHETHER UNDER THIS WARRANTY OR UNDER ANY WARRANTY IMPLIED BY LAW, FOR ANY INDIRECT OR CONSEQUENTIAL DAMAGES FOR BREACH HEREOF OR THEREOF.

Note: Some states prohibit limitations on the duration of implied warranties and on the exclusion of indirect or consequential damages; and so the limitation on implied warranties and on incidental and consequential damages may not be applicable to you.

RESPONSIBILITY OF CUNO

CUNO's responsibility under this warranty shall be to repair at its expense, at no charge to the original purchaser-consumer, any product that is actually defective, malfunctioning, or otherwise in violation of this warranty. If CUNO for any reason cannot repair a Product covered hereby within two (2) weeks after receipt of the original purchaser-consumer's notification of a Warranty claim, then CUNO's responsibility shall be, at its option, either to replace the defective Product with a compa-

table new unit at no charge to the consumer or to refund the full purchase price. CUNO's obligations of repair, replacement, or refund are conditioned upon return of the defective Product to CUNO.

If any Product covered hereby is actually defective within the terms of this Warranty, then CUNO will bear all the reasonable and proper shipping and mailing charges actually incurred in the consumer's return of the Product set forth herein. If the Product proves not to be defective within the terms of this Warranty, then all costs and expenses in connection with the processing of the consumer's claim hereunder shall be borne by the consumer.

RESPONSIBILITY OF THE CONSUMER

The original purchaser-consumer's sole responsibility in the instance of a warranty claim shall be to notify CUNO of the defect, malfunction, or other manner in which the terms of this Warranty are violated. You may secure performance of obligations hereunder by (in writing):

1. Identifying the Product involved (by model or serial number or other sufficient description that will allow CUNO to determine which product is defective).
2. Specifying where, when, and from whom the Product was purchased.
3. Describing the nature of the defect, malfunction, or other violation of this Warranty.
4. Sending such notification together with the defective Product and \$5.00 check or money order to cover postage and handling to:

**CUNO Incorporated,
400 Research Parkway, Meriden, Connecticut 06450, USA**

**THIS WARRANTY GIVES YOU SPECIFIC LEGAL RIGHTS,
AND YOU MAY ALSO HAVE OTHER RIGHTS, WHICH VARY
FROM STATE TO STATE**



CUNO and ScaleGard are trademarks of 3M Company used under license.
John Guest is a trademark of John Guest International Limited.

© 2007 3M Company. All rights reserved.

CUNO Incorporated
400 Research Parkway
Meriden, CT 06450, USA
Toll Free: 1-888-218-CUNO
Worldwide: 203-237-5541
Fax: 203-238-8701
www.cunofoodservice.com • www.cuno.com