

334im

335im

336im

installation manual

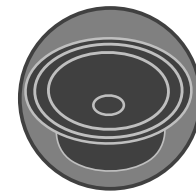



declaration of conformity

manufacturer's name: analog and digital systems, inc
manufacturer's address: 300 wildwood avenue
woburn, ma 01801
usa

declares, that the product:

product name: 334im
335im
336im

conforms to the following standards:

EN 50 081-1/1992
EN 50 082-1/3.1995

european contact:

Axel Perlwitz
audiomax GmbH
Heilbronn Germany

table of contents

introduction.....	3
about this manual.....	3
features of your 3-series loudspeaker.....	4
warnings and tips.....	5
system planning.....	5
amplifier requirements.....	6
mounting locations.....	6
controls and connections.....	6
tweeter level control.....	6
midrange contour.....	7
connections to the amplifier.....	7
speaker wiring.....	7
speaker wire selection.....	7
polarity and phasing.....	7
termination.....	8
speaker mounting.....	8
woofer installation.....	8
woofer mounting.....	8
tweeter installation.....	10
angle direction.....	10
crossover installation.....	12
connecting the system.....	12
connections to crossover network and radio or amplifier.....	13
bi-amplified connections to the crossover network.....	13
bi-wired connections to the crossover network.....	14
troubleshooting.....	15
jack pinouts.....	16
specifications.....	16
warranty information.....	17
ce declaration of conformity.....	19

introduction

Thank you for choosing this *a/d/s/* integrally mounted automotive loudspeaker. Your new loudspeaker system is the latest innovation in reference quality automotive loudspeakers. Its unique combination of high technology design and real-world convenience features make it the ideal addition to any quality music system. *a/d/s/* takes great pride in manufacturing products that truly stand the test of time, from their renowned mini-speakers to whole house systems of the grandest proportion. With a minimum of care, this *a/d/s/* product will provide years of trouble-free satisfaction. Keep this manual in a safe place, it's likely you will use it again & again!

about this manual

To get the most from your *a/d/s/* 3-series loudspeaker, we recommend that you read this manual thoroughly before using. If there is anything that you do not fully understand, please consult with your *a/d/s/* dealer before attempting the installation.

features of your 3-series loudspeaker

molded woofer basket - the back bone of any good woofer is its basket. It provides the proper alignment and support structure for the magnet while the very thin braces guarantee a minimum of early reflections off the basket that would be ordinarily transmitted as sonic colorations through the cone.

tweeter level control - a three position control adjusts the volume of the tweeter with respect to the midrange.

midrange contour control - a two position switch offers a frequency response correction circuit to adjust for flat frequency response in the car on axis or off axis.

swivel-mount tweeter - unique rotatable angle mount allows the high quality ferrofluid cooled neodymium tweeter to be angled towards the listener (only in the 335im and 336im).

bi-amplifiable / bi-wireable - the passive crossover supplied with this system is bi-amplifiable or bi-wireable; typically only available in high quality audiophile home loudspeakers.

solid state tweeter protection - advanced protection circuitry provides protection for the tweeter against overpowering or amplifier clipping.

stifflite III woofer cone - mineral enhanced copolymer which is injection moulded to provide the ideal balance of mass to stiffness.

vented voice coil - magnet structure cooling vent enhances power handling capabilities of the woofer.

extended center pole - woofer magnet geometry provides a symmetrical magnetic pattern to reduce THD.

warranty information

There are two things you must do to ensure trouble free service in the event you need warranty repairs.

- 1 - Keep your original sales receipt in a safe place. A copy of the receipt will be required to obtain warranty service.
- 2 - Be sure your retail dealer has written the date, the model number, and the serial number (if applicable) of the Product on the receipt.

To give yourself an extra measure of protection, make a separate record of the information about your purchase and keep it in a safe place. In the event you misplace the sales receipt, your dealer may be able to give you a copy.

Take a moment now to read the terms of your warranty. Check to be sure your sales receipt is dated and has the Product model number and serial number (if applicable) on it. Then put it away in a safe place.

When shipping a Product in for service:

- Enclose a copy of your original sales receipt that has the date, the Product model number and serial number (if applicable) written on it.
- Always ship Products in the complete original packing material.
- Avoid shipping Products via the Postal service. If you must use the Postal service, be sure to register and insure the package.

a/d/s/ Limited Warranty

Analog and Digital Systems, Inc. (a/d/s/) warrants to the original consumer purchaser of the a/d/s/ Products described in this manual, that the Product will be free from defects in materials and workmanship for a period of one (1) year after the date of purchase. If the product is installed by an authorized a/d/s/ retail dealer, the warranty is extended to three (3) years, a/d/s/' sole obligation under this warranty shall be to provide, without charge, parts and labor necessary to remedy the defects, if any, that appear during the warranty period.

This warranty is the sole and exclusive express warranty given with respect to the Product. All other express warranties are hereby excluded. Neither a/d/s/ nor the authorized dealer who sells the Product is responsible for indirect, incidental, or consequential damages. Some states do not allow the exclusion or limitation of incidental or consequential damages, so the above limitation or exclusion may not apply to you. This warranty gives you specific legal rights and you may also have other rights which vary from state to state.

IMPORTANT - Keep your original sales receipt. Be sure the retail dealer has written on it the date, model number, and serial number (if applicable) of the Product. This information is required for warranty service.

This warranty is limited to:

- Products purchased from authorized a/d/s/ retail dealers in the United States. a/d/s/ will supply a list of authorized dealers on request.

In order to obtain warranty service you must:

- Return the Product, freight prepaid, to the a/d/s/ dealer from which it was purchased, an authorized a/d/s/ independent service agency, or to a/d/s/. If necessary you may call a/d/s/ Customer Service Department for the names and addresses of authorized independent service agencies in your area.
- Provide proof of purchase in the form of a copy of your original sales receipt. The date, model number, and serial number (if applicable) of the Product must be written on the sales receipt.

This warranty does not cover:

- Damage that is the result of misuse, abuse, accident (including but not limited to damage by water), faulty hookup, defective or maladjusted associated equipment, or the use of the Product with equipment for which it was not intended.
- Cosmetic defects that appear more than thirty (30) days after the date of purchase. Cosmetic damage caused by improper handling is also excluded.
- Products that are used for commercial purposes.
- The cost of removing or reinstalling the Product.
- Damage that occurs while the Product is being shipped to whoever will service it. See the information above regarding shipping procedures.

This warranty is void if:

- The Product identification or serial number label is removed or defaced in any way.
- The Product is serviced or repaired by any one other than a/d/s/ or an authorized a/d/s/ dealer or service agency.

jack pinouts

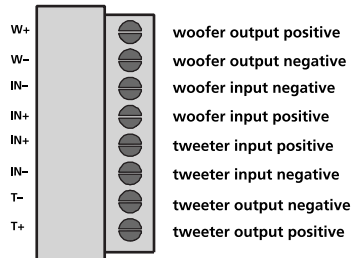

specifications

	334im	335im	336is
frequency response +/-3dB:	48Hz to 22kHz	48Hz to 22kHz	40Hz to 22kHz
sensitivity 2.83 volt RMS pink noise measured at 1 meter:	85dB	90dB	91dB
impedance, nominal:	4 Ohms	4 Ohms	4 Ohms
recommended amplifier power watts RMS:	15 to 100	15 to 100	15 to 150
dimensions – woofer/midrange transducer			
mounting depth (woofer):	2" / 50mm	2 3/8" / 60mm	2 7/16" / 63mm
overall height:	2 5/16" / 59mm	2 11/16" / 69mm	2 15/16" / 79mm
overall maximum diameter:	4 7/8" / 123mm	6" / 152mm	6 1/2" / 165mm
maximum height above panel without grille:	11/16" / 18mm	1/2" / 13mm	5/8" / 16mm
maximum height above panel with grille:	3/4" / 20mm	3/4" / 20mm	15/16" / 24mm
maximum grille diameter:	5 3/16" / 132mm	6 1/2" / 166mm	7 1/8" / 181mm
cutout size:		4 5/8" / 118mm	4 15/16" / 125mm
dimensions – crossover network			
length/width/height:	5 3/16" x 3 1/2" x 1 5/8" 132mm x 89mm x 42mm		
Thiele-Small specifications			
free air resonance (F _s):	52.0Hz	57.2Hz	57.1Hz
electrical damping (Q _e):	.82	.34	.47
mechanical damping (Q _m):	4.50	4.87	6.00
total damping (Q):	.69	.32	.44
equivalent volume of compliance (V _{as}) cubic feet / liters:	0.19 / 5.5	0.26 / 7.41	0.46 / 13.0
effective cone area (S _d) in ² :	8.56	14.1	18.9
center to peak linear excursion (X _{max}):	.16" / 4.0mm	.16" / 4.0mm	.16" / 4.0mm
peak to peak excursion:	1/2" / 12.7mm	1/2" / 12.7mm	3/4" / 19.0mm
voice coil DC resistance (R _v):	3.1	3.1	3.1
voice coil diameter:	1" / 25.4mm	1" / 25.4mm	1" / 25.4mm
voice coil length (winding length):	.45" / 11.5mm	.45" / 11.5mm	.45" / 11.5mm

a/d/s/ subscribes to the philosophy of continuous product development therefore the specifications may change without notice.

 a/d/s/ tweeters are constructed in concert with the Ferrosound program and use Ferrofluid to provide increased power handling, decreased distortion, minimum electrical impedance change, higher linearity, and smoother frequency response.

warnings and tips

Study your automobile thoroughly before you drill or cut any holes. Take extra care when working near gas tanks, gas lines, brake or hydraulic lines and electrical wiring.

Wear eye and ear protection when using power tools.

Keep the woofers and tweeters away from metal filings and shavings. Once foreign objects are stuck to the magnets or tweeter dome, it will be virtually impossible to remove them. Keep the tweeters in their protective bags until final mounting to prevent any possibility of metal dust or chips from passing through the grille and accumulating on the dome.

Exercise caution when working with the 3-series with the grille removed. A slip of the hand with a screwdriver or other tool can result in irreparable damage to the cone or dome. Do not touch the cone or dome.

Do not install the components where they will be subject to excessive heat, moisture or dust; or where they will be kicked or repeatedly bumped or brushed.

Make absolutely sure that the woofer is connected to the lowpass output and the tweeter is connected to the highpass output of the crossover network. If these connections are reversed, low-frequency signals will be fed to the tweeter without fuse protection. In this case, the tweeter may be damaged. Such damage is not covered by the warranty.

When removing or installing the grille on the 3-series, be careful not to brush the woofer's rubber surround or the tweeter's dome with the edge of the grille. Cutting or tearing the surround or dome will destroy the unit.

Never run wires outside or beneath the vehicle where they can be snagged by road hazards or the moving parts of the vehicle. Use existing wire channels, sills, panels and molding strips inside the automobile to hide the wiring for neat appearance and safety.

Make sure your radio/cassette/cd player and or other equipment is turned off while connecting the 3-series speaker terminals. Turn on the various components and slowly advance the volume control **only** after checking and double checking all connections

Note: if sound is weak or distorted, immediately turn down the volume and see the section entitled troubleshooting.

system planning

Proper system planning is the best way to maximize performance. By planning your installation carefully you can avoid situations where the performance or reliability of your system is compromised. Your authorized a/d/s/ dealer has been trained to know how to maximize your systems sonic potential. They are a valuable resource in helping you with your system design and installation.

amplifier requirements

a note on power handling

Each 3-series speaker system requires a minimum of 20 Watts per channel to achieve reasonable listening volumes in a moving automobile without clipping the amplifier. a/d/s/ recommends 150 Watts per channel as a maximum so as not to exceed the thermal or mechanical limitations of the speaker system. Any amplifier between 20 watts and 150 watts per channel may be used. If you choose to use an amplifier with more power than 150 Watts be very careful, you can damage the speaker system if played too loud.

All a/d/s/ loudspeakers will produce reasonable volume levels in the automotive environment using moderate amplifier power. However, the use of a low powered amplifier to try and attain very high volume levels can lead to overdriving the amplifier. This will generate high distortion levels which can easily damage loudspeakers, even when the amplifier's rated power is far below the maximum rated power of the loudspeaker.

As a rule, do not turn the volume up above the point where you hear distortion on musical peaks from either an overdriven amplifier or mechanical noise from an overstressed speaker. For the best performance and reliability, select an amplifier with slightly more than the maximum power you are likely to need to generate the desired volume levels. This margin of reserve power will ensure that the amplifier will not attempt to deliver more than its design allows.

Warning: Excessive sound pressure level can permanently damage your hearing. The maximum volume levels attainable with a/d/s/ speakers, combined with high-power amplification, may exceed safe levels for extended listening. When listening at high volume levels always use hearing protection or turn it down!

mounting locations

There are many possible choices of mounting locations. The automobile factory locations will usually dictate the speaker mounting position.

controls and connections

tweeter level control

The three position switch in the crossover box labeled low mid high adjusts the relative volume of the tweeter with respect to the midrange. The mid position is referenced as equal output from the midrange and tweeter. The hi position offers 3dB more output from the tweeter. The low position is 3dB less output.

Adjust this control to your listening preference.

troubleshooting

symptom	probable cause	remedy
no output	source or amplifier not turned on	check source or amplifier and fix as needed
	audio input not connected or no output from source protection circuit activated	check RCA connections and signal integrity, fix or replace as needed turn down volume. Protection will self reset
	speaker wires not connected	check speaker wires and fix or replace as needed
audio cycles on and off	speaker damaged	check system with known working speaker and fix or replace as needed
	thermal protection engaged	check that amplifier has adequate ventilation check speaker impedance load
	Loose or poor audio input	check RCA, power and speaker connections and fix or replace as needed
distorted output	preamp volume set too high. exceeding maximum capability of amplifier. Impedance load to amplifier too low	check volume of preamp and adjust appropriately check speaker impedance load, if below 1 ohm rewire the speakers to achieve a higher impedance
	shorted speaker wires	check speaker wire connections and fix or replace as needed
	speaker not connected properly	check speaker wiring and fix or replace as needed. refer to the speaker wiring section of this manual for detailed instructions
	speaker damaged	check system with known working speaker and fix or replace as needed
poor bass response	speakers wired with wrong polarity causing cancellation at low frequencies	check speaker polarity and fix as needed
lack of stereo separation	speakers wired with wrong polarity. stereo / bridge switch set to bridge position speaker connected across wrong output terminals	check speaker polarity and fix as needed set switch to stereo position check that the speaker wires are not connected to the bridged terminals and fix as needed
	source set to mono	check source and adjust controls as needed

analog and digital systems
one progress way
wilmington, ma 01887
usa

If you want to consult the factory, write or call our customer service department:

Customer Service Department
analog and digital systems, inc
300 wildwood avenue
woburn, ma 01801
ph 781.729.1140
fax 781.729.3535

bi-wire connections to the crossover network

connections to the woofer and tweeter are the same as the normal wiring method. Connect the amplifier to the tweeter to the terminals marked tweeter input. Connect the woofer amplifier to the woofer input terminals with another run of wire.

Important note - you must cut the jumpers that connect the low frequency and high frequency sections of the crossover. See diagram . Failing to cut these jumpers could cause damage to the amplifiers or the crossover.

for biamp operation cut these jumpers

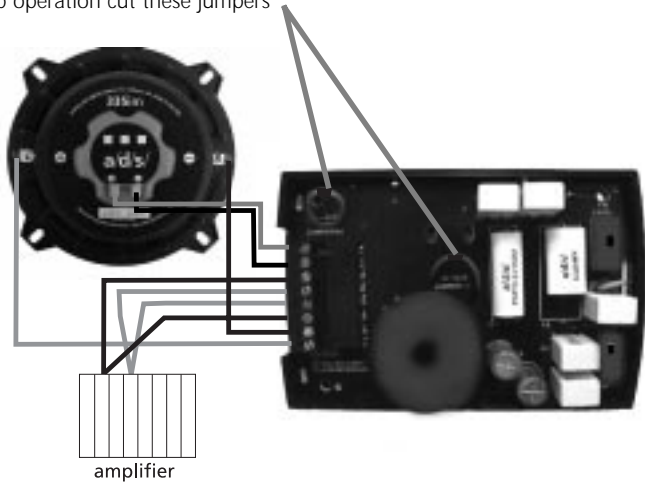

midrange contour

The two position switch labeled car / demo adjusts the frequency response of the midrange driver. The car position is optimized for in car off axis listening. The demo position offers flat frequency response when the speakers are able to be placed on axis to the listener. This control will effect the presence or forwardness of the sound stage. You can experiment with both positions and set to your preference.

connections to the amplifier

The 3-series crossover is supplied with a removable screw type connector. Strip the wire from the amplifier about 1/4" from the end and insert into the connector input + and - positions and tighten the set screws. Strip the wire from the woofer and insert into the + and - positions for the crossover woofer output. Follow the same procedure for the connection to the tweeter. The 3-series passive crossover has two sets of input terminals, this allows the system to be bi-wired or bi-amplified. If you select to use one of these wiring schemes you must cut the jumpers in the crossover to electrically separate the high-pass and low-pass sections (see diagram on page 14 for location of jumpers).

To bi-amplify the system you will need two stereo amplifiers (or 4 amplifier channels) one for the tweeters and one for the woofers.

If you choose to bi-wire the system, connect the high-pass terminals to the amplifier and connect the low-pass terminals to the same amplifier with another set of speaker wires.

Be sure to connect the positive crossover terminals to the positive speaker terminals and positive amplifier terminals, also ensure that the negative crossover terminals connect to the negative amplifier and speaker terminals.

Once all of the wires are attached to the connector and the crossover is mounted, the connector can be plugged into its mating receptacle on the crossover.

speaker wiring

speaker wire selection

Use insulated two-conductor stranded wire to connect the 3-series crossover to the speakers and amplifier. The size of the wire can have an audible effect of the performance of the system. Standard 18 gauge "zip cord" will work, but can result in lower output or unpredictable frequency response. For wire runs of 50 feet or less, we recommend 16 gauge or larger wire. The crossover connector will accept up to 14 gauge wire.

polarity and phasing

The polarity - the positive / negative orientation of the connections - for every speaker and amplifier connection must be consistent so all the speakers will be in phase. When the polarity of one connection is reversed, bass output is reduced and stereo imaging is degraded. All wire is marked so you can identify the two conductors. There may be ribs or a stripe on the insulation of one conductor. Or the wire may have clear insulation with different color conductors (copper and silver). Or there may be polarity indications printed on the insulation. Identify the positive and negative conductors and be consistent with every speaker and amplifier connection.

If one or more pairs of amplifier channels are bridged, there are special methods for connecting the speaker wires. Instead of connecting the speaker wires to a positive (red) and negative (black) set of terminals, the speaker wires are connected the positive terminals of the bridged channels. Of course, proper polarity of the connections is still important, so one of the terminals must be designated as positive and one as negative.

termination

The woofer and the tweeter use .187 spade lugs for electrical connections. Use standard .187 female quick disconnects to attach wires to the speaker.

speaker mounting

woofer installation

The 3-series woofer will fit into standard factory mounting locations using the existing mounting holes in the automobile. The woofer uses .187 spade type terminals for electrical connections. To connect the woofer, use .187 or .205 female quick disconnects of a size appropriate for the wire gauge you chose. You may also solder wire directly to the terminals. If you choose to solder the wires, be careful not to use excessive heat so you do not melt the plastic around the terminal, which is not covered by the warranty

Remove the trim panels and inspect the installation locations before you cut and drill the holes required to mount the woofer. Removing the panel will also make it much easier to route wiring inside the door. Look for original equipment speaker installation cutouts that can be used to install the 3-series woofers with little or no modifications. Use the template supplied to help you locate and mark the holes needed to install the speakers.

If the planned installation location is in a door panel be sure the speaker will not interfere with the window lowering mechanism. Be sure that the speaker wires clear all moving parts inside the door.

For each woofer you will need to cut one large hole and drill small holes around the circumference. If the mounting surface is covered by carpet or fabric, use a knife or razor to cut the material away from the holes and cutting path. This prevents material or fibers from becoming tangled in the drill bit or cutting blade.

If you are using the sheet metal screws provided in the hardware kit, drill the four speaker mounting screw holes with a 1/8" / 3mm drill.

Clean the work areas of all filings and shavings with a vacuum cleaner before you proceed with woofer mounting.

woofer mounting

Route the speaker wire from the woofer installation locations to the crossovers. Pull the wire through the installation hole and attach the terminals on the ends to terminals on the speakers. Connect the positive wire to the positive (+) terminal, which is indicated by a "+" on the speaker magnet. See the information in the speaker wiring section of this manual and the wiring diagrams. Push the wire back into the area behind the installation location and be sure it will not interfere with the speaker.

Adhere the supplied foam gasket strip to the mounting surface of the speaker. This will ensure an air tight seal, which is required to achieve the best bass performance.

When installing the speakers drive the supplied sheet metal screws by gradually tightening them in turn. Drive the screws in until the speaker is well seated, but take care not to over-tighten the screws.

Each of the 3-series woofers is installed in a slightly different way. See the following illustrations

connections to crossover network and radio or amplifier

route the wires connected to the input terminals on the front of the crossover network to the power amplifier (or, if you are not using a separate power amplifier, the in-dash radio/tape or CD player). Connect the wires to the amplifier outputs as recommended by the manufacturer of the unit. Make sure there are no stray strands of wire which could cause a short circuit. Observe left / right and polarity markings.

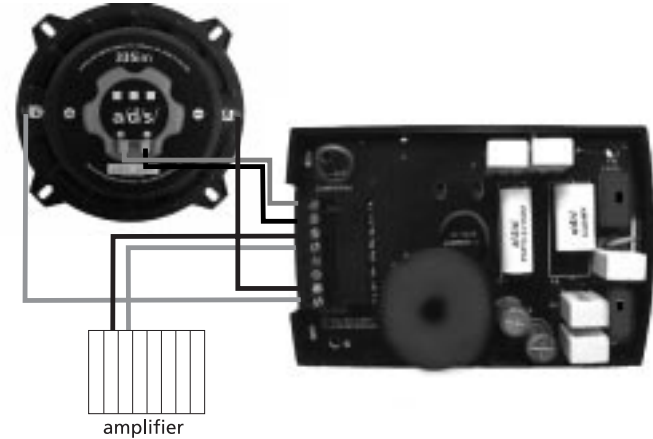

bi-amplified connections to the crossover network

connections to the woofer and tweeter are the same as the normal wiring method. Connect the amplifier you have chosen for the tweeter to the terminals marked high input. Connect the woofer amplifier to the low input terminals.

Important note - you must cut the jumpers that connect the low frequency and high frequency sections of the crossover. See diagram . Failing to cut these jumpers could cause damage to the amplifiers or the crossover.

for biamp operation cut these jumpers

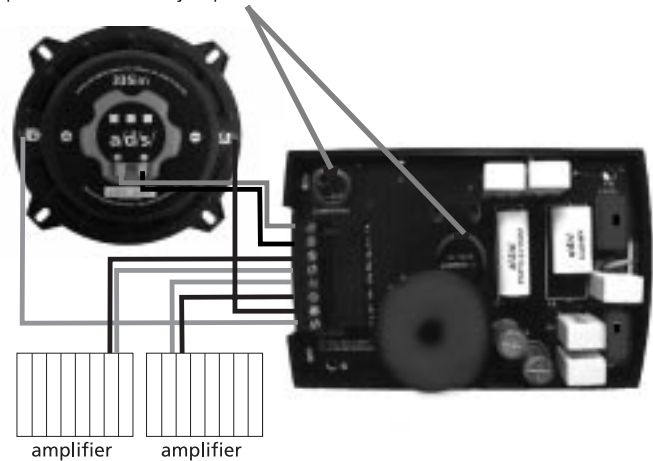

crossover installation

bi-wiring / bi-amping

The 3-series allows conventional wiring, bi-wiring, or bi-amping using the supplied passive crossovers.

While conventional wiring will provide excellent sound, bi-wiring or bi-amping will further enhance the performance in no-compromise systems.

Bi-wiring uses a separate pair of speaker wires for the high frequency and low frequency signal between an amplifier channel and its associated crossover network. This gives you the option of choosing wire which may have slightly different sonic characteristics in order to optimize performance of each frequency range. Also, it reduces the overall wiring resistance between the crossover and amplifier, much like the use of larger gauge wire. This option provides the most benefit when the crossover network is mounted a long distance away from the amplifier. If the crossover is mounted close to the amplifier it is doubtful that there will be an appreciable difference between bi-wiring and conventional wiring.

Bi-amping is similar to bi-wiring except that it uses a separate amplifier channel for the high-frequency and low-frequency sections, instead of the single amplifier channel used in conventional and bi-wired connections. Bi-amping provides the additional advantages of reducing amplifier distortion and allowing the amplifier's level controls to provide an additional level of fine-tuning not possible with the tweeter-level switch alone. In addition, at high power levels, a bi-amplified connection protects the tweeter from amplifier clipping, which is most likely to occur on channels driving the midrange, due to the higher energy levels of midrange signals. When bi-amping using the passive crossovers, the midrange low-pass filter and tweeter high-pass filter on the amplifier or external electronic crossover should be bypassed.

Carefully route the wires from the 3-series tweeter and woofer to the crossover mounting location. The crossover installation location should be reasonably accessible to allow easy connection of the wires, tweeter level adjustment and midrange contour selection. If the crossover must be mounted in an inaccessible location make the speaker wire connections and adjustments before final installation. Be sure the installation location has adequate clearance to allow the removal and replacement of the cover.

Mounting the crossover requires removing the top cover of its housing. Grasp the top cover at the front and back. Compress the cover slightly and lift it off the bottom of the housing.

Mounting the crossover requires four holes in a rectangular pattern 2 13/16" x 4 1/4" on a flat surface. Use the provided template as a guide for drilling the mounting holes.

Align the mounting holes in the bottom half of the crossover unit with the holes you have drilled at the installation site. Pass the four #6 x 1 1/4" screws through the holes in the crossover unit, and tighten them until the assembly is firmly in place. As before, do not over-tighten; this is especially important if the mounting surface is not perfectly flat.

After all the connections and any necessary adjustments have been made snap the cover back in place.

connecting the system

Trim the speaker wire as needed. Strip about no more than 1/4" (6mm) of the insulation from the ends. Twist the exposed strands thoroughly to prevent any loose strands from causing a short circuit. If possible "tin" the wire with a soldering iron. The wires attach to a removable connector strip, in its attached position the screws face the bottom of the crossover.

Insert the prepared wire into the appropriate location (see diagram or refer to the crossover circuit board) in the connector strip and tighten the screws to secure the wires in place.

Note the polarity marking on the crossover circuit board.

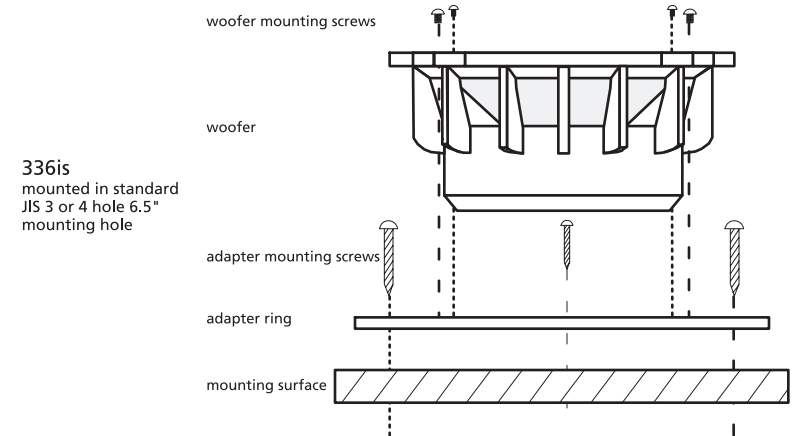
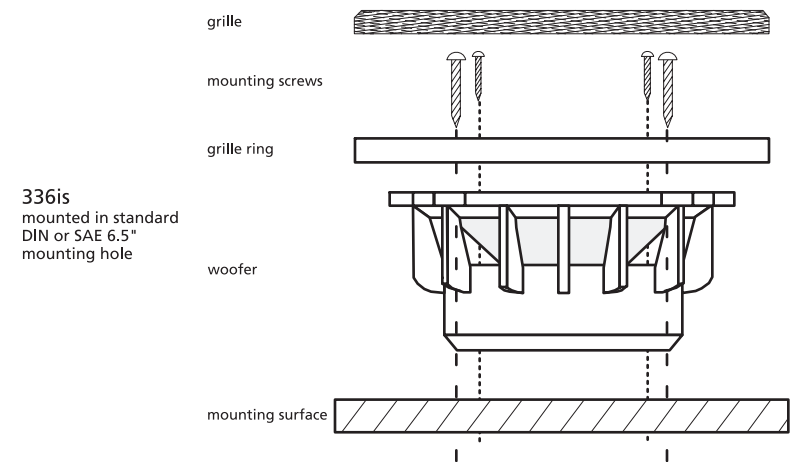
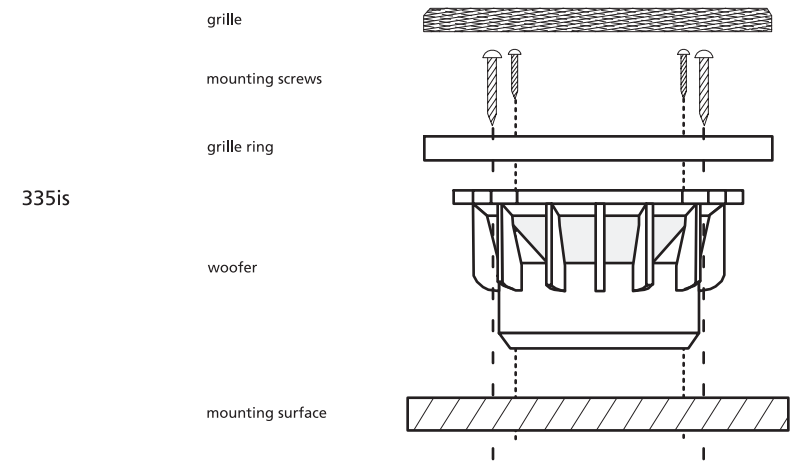

rotating the tweeter

Grasp the knob on the back side of the speaker, and gently turn it to the desired position. *a/d/s/* recommends that you start with the tweeter angled so it points directly at the listening area. Feel free to experiment with the position that gives you the most pleasing sound quality. **NOTE:** this feature only applies to the 335im, and 336im. The tweeter of the 334im does not rotate.

