

DURA-POWER 180°F BOOSTER MODELS

Dura-Power® commercial electric water heaters are designed to boost the water temperatures for applications such as commercial dishwashers, which require very high temperature sanitizing rinse—typically 180°F. Both 5-gallon countermount “CMC” models and 20-gallon “SU” models are available with inputs up to 54 kW. Are models are also available with an optional stainless steel tank for use with deionized water.

FEATURES

INCOLOY-SHEATH HEATING ELEMENTS STANDARD

- Industrial-grade Incoloy sheathed heating elements are designed for rugged long-lasting commercial service and can withstand sheath temperatures up to 1500°F
- Each heating element has three separate heating loops, which provides more heating surface, lower watt density and maximum recovery efficiency
- Pre-wired leads provide excellent protection against oxidation and scaling
- Input options from 6 kW to 54 kW, recoveries from 25 to 221 gallons per hour (gph) at 100°F rise
- Deionized models equipped with stainless steel standard elements

A. O. SMITH GOLDENROD ELEMENTS OPTIONAL

- Patent-pending 24k gold-plated sheath plus medium watt-density ensures even longer element life
- Higher resistance to scale build-up, compared to Incoloy elements
- Three-year warranty against failure due to lime scale build-up
- Not available on deionized models

STANDARD VOLTAGES FOR EASY INSTALLATION

- Single-phase and three-phase
- Single-phase 208V and 240V are field-convertible to three-phase
- CMC models only, 208V and 240V at 24 kW and below are supplied as phase-convertible units (single- to three-phase and vice versa)
- 277V single-phase also available – Contact A. O. Smith for 120V circuit availability

IMMERSION THERMOSTAT FOR EFFICIENT CONTROL

- Close-differential, immersion-type thermostat for superbly accurate temperature control
- Adjustable from 140°F to 185°F
- Manual reset, high-temperature cutoff

HEAVY-DUTY MAGNETIC CONTACTORS

- UL-rated 100,000 cycles

FACTORY-WIRED, 120V CIRCUIT CONTROLS

- 120V control circuit powered by fused transformer
- Eliminates need for 120V service connection

MODELS CMC/SU-6 through CMC/SU-54



Certified to NSF/ANSI 61





POWER-CIRCUIT FUSING FOR SYSTEM PROTECTION

- Safeguards elements and contactors from short circuits, overloading and line surges
- Required by National Electric Code and UL when current draw exceeds 120 A

ALL STAINLESS STEEL JACKET

- Cleans easily, corrosion resistant, hinged for easy serviceability
- Standard on CMC models, optional on SU models

GLASS-LINED TANK, ASME TANK CONSTRUCTION

- Specifically developed for high-temperature water heater use
- Provides long-lasting protection against corrosion
- Equipped with anode rod for additional corrosion protection
- Stainless steel tank on deionized models

MAXIMUM HYDROSTATIC WORKING PRESSURE: 150 PSI

FACTORY-INSTALLED TEMPERATURE & PRESSURE RELIEF VALVE MEETS ASHRAE/IESNA 90.1

THREE-YEAR LIMITED TANK WARRANTY

- For complete information, consult written warranty or contact A. O. Smith

OTHER DURA-POWER CMC AND SU SERIES STANDARD FEATURES:

- SIMPLIFIED, COLOR-CODED CIRCUITRY FOR EASE OF SERVICE
- ASME T & P RELIEF VALVE
- PRESSURE REDUCING VALVE WITH BYPASS CHECK AND STRAINER
- TEMPERATURE/PRESSURE GAUGES

OTHER DURA-POWER CMC AND SU SERIES OPTIONS:

- STAINLESS STEEL TANK
 - For deionized water
- LOW-WATER CUTOFF
 - Probe-type electric low-water cutoff
 - Prevents energizing of elements when low-water condition exists (automatic reset)
- UNDERCOUNTER MOUNTING PAN FOR CMC MODELS
- DUAL INDICATING/PILOT LIGHTS AND SWITCH
 - Lights indicate when elements are on, switch gives positive on-off control of control circuit
- SHOCK ABSORBER REDUCES WATER HAMMER

INPUT CAPACITY AND RECOVERY

MODEL NUMBER	STANDARD KW INPUT	GPH OR LPH	RECOVERY—GALLONS OR LITRES PER HOUR AT DEGREE RISE*		
			40°F 22°C	100°F 56°C	140°F 78°C
CMC-6 SU-6	6	GPH	62	25	18
		LPH	234.7	94.6	68.1
CMC-6 SU-6	9	GPH	92	37	26
		LPH	348.2	140	98.4
CMC-6 SU-6	12	GPH	123	49	35
		LPH	465.6	185.5	132.5
CMC-6 SU-6	15	GPH	154	61	44
		LPH	582.9	230.9	166.5
CMC-6 SU-6	18	GPH	184	74	53
		LPH	696.4	280.1	200.6
CMC-6 SU-6	20	GPH	205	82	58
		LPH	775.9	310.4	219.5
CMC-6 SU-6	24	GPH	246	98	70
		LPH	931.1	370.9	265
CMC-6 SU-6	30	GPH	307	123	88
		LPH	1162	465.6	333.1
CMC-6 SU-6	36	GPH	369	148	105
		LPH	1396.7	560.2	397.4
CMC-6 SU-6	45	GPH	461	184	132
		LPH	1744.9	696.4	499.6
CMC-6 SU-6	54	GPH	554	221	158
		LPH	2096.9	836.5	598

For deionized water models with stainless steel tanks, add "D" to model number.
Examples CMCD-6, SUD-6. NSF recovery ratings = above ratings x .98.

CMC MODELS

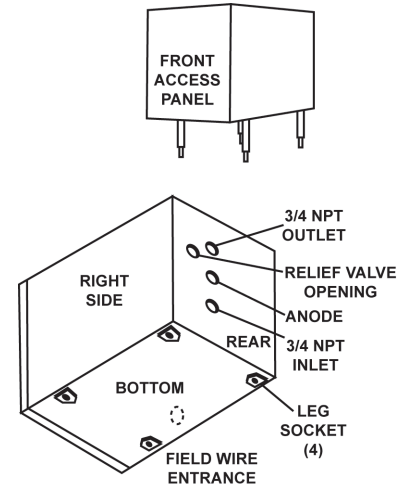

SU MODELS

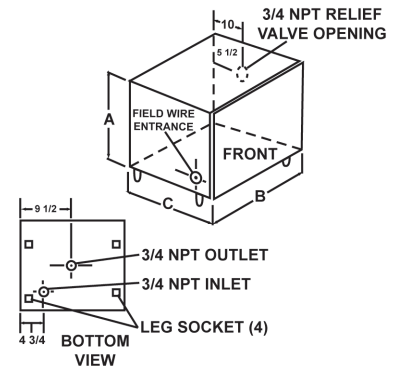

DIMENSIONS AND WEIGHT

MODEL NUMBER	GALLONS OR LITRES	CAPACITY	DIMENSIONS IN INCHES				SHIPPING WEIGHT
			HEIGHT A	WIDTH B	DEPTH C	INLET/OUTLET	STANDARD
CMC-6 through CMC-18	U.S. Gallons	5	13.75	13	23.5	3/4	80 lbs.
	Litres		34.9	33	55.2	1.91	36.4 kg
CMC-20 through CMC-54	U.S. Gallons	5	12	18	23.5	3/4	96 lbs.
	Litres		30.5	45.7	57.2	1.91	43.6 kg
CMC-6 through CMC-54	U.S. Gallons	20	25	22.25	23	3/4	200 lbs.
	Litres		63.5	56.5	58.4	1.91	90.9 kg

WATTAGE AND VOLTAGE

KW INPUT	AVAILABLE MODEL		NUMBER OF IMMERSION HEATERS	IMMERSION HEATER WATTAGE	FULL LOAD CURRENT IN AMPERES							
	CMC SERIES	SU SERIES			SINGLE PHASE				THREE PHASE			
					208V	240V	277V	480V	208V	240V	480V	
6	CMC-6	SU-6	1	6,000	28.8	25	21.7	12.5	16.7	14.4	7.2	
9	CMC-9	SU-9	1	9,000	43.3	37.5	32.5	18.8	25	21.7	10.8	
12	CMC-12	SU-12	1	12,000	57.7	50	43.3	25	33.3	28.9	14.4	
15	CMC-15	SU-15	1	15,000	72.1	62.5	54.2	31.3	41.6	36.1	18	
18	CMC-18	SU-18	1*	18,000	86.5	75	65	37.5	50	43.3	21.7	
20	CMC-20	SU-20	2	10,000	96.2	83.3	72.2	41.7	55.5	48.1	24.1	
24	CMC-24	SU-24	2	12,000	115.4	100	86.6	50	66.6	57.7	28.9	
30	CMC-30	SU-30	2	15,000	144.2	125	108.3	62.5	83.3	72.2	36.1	
36	CMC-36	SU-36	2	18,000	173.1	150	130	75	99.9	86.6	43.3	
45	CMC-54	SU-45	3	15,000	216.3	187.5	162.5	93.8	124.9	108.3	54.1	
54	CMC-54	SU-54	3	18,000	N/A	225	194.9	112.5	149.9	129.9	65	

*208V models use on additional immersion heater
**Each immersion heater contains three electric elements



Commercial Electric Water Heaters

SUGGESTED SPECIFICATION

The water heater(s) shall be A. O. Smith Dura-Power Model(s) CMC/SU _____ rated at _____ KW, _____ volts, _____ -phase, 50/60 cycle AC, and constructed in accordance with ASME Code and shall bear appropriate symbol and be listed with the National Board as required. Heater shall be listed with Underwriters Laboratories and approved by National Sanitation Foundation.

Glass-lined tank(s) shall be _____ gallon capacity with 150 psi maximum working pressure/ASME Code. Tank shall be cathodically protected with adequate extruded magnesium rod. All internal surfaces of the heater(s) exposed to water shall be glass-lined with an alkaline borosilicate composition fused to steel. For deionized, substitute: Stainless tank(s) shall be _____ gallon capacity with 150 psi working pressure/ASME Code.

Elements shall be commercial-grade, medium watt density, triple-loop construction Incoloy sheathed or Goldenrod elements _____. For deionized, substitute: Elements shall be commercial-grade, type 316 L stainless steel sheathed. Elements shall be switched through magnetic contactor(s). Fused 120V control circuit shall include manual reset, high-temperature cut-off switch and immersion-style operating thermostat(s). Low-water cut-off (optional) to prevent element burnout due to possible low-water conditions. Straight-line rectangular cabinet shall be baked enamel with stainless steel front panel (SU models only). All stainless steel jacket (CMC models only) shall provide full-size access to control and elements for ease in servicing and shall enclose tank with fiber-class insulation.

Heater tank shall have a three (3) year limited warranty as outlined in the written warranty.