

Master-Fit[®] BOOSTER MODELS

**BTR-151
through
BTR-201**

The Master-Fit[®] BTR-151 and BTR-201 are designed for installation in “booster” applications, to supply commercial dishwashers with very high temperature water... usually 180°F. A booster water heater is normally used in conjunction with a standard water heater water delivering hot water at a lower temperature to meet the non-dishwashing needs of a restaurant or other foodservice application.

With a 32-gallon storage tank, these compact units measure only 45" high, and hot and cold water connections can be made in the top, front or rear, for installation versatility.

THE ELIMINATOR™ SELF-CLEANING SYSTEM

- Designed to significantly reduce or eliminate buildup of lime, sand and other sediment inside the tank
- Reduced sediment buildup helps Master-Fit water heaters maintain their rated energy-efficiency and reduce water heating costs
- Self-cleaning system also helps prolong tank life

BUILT-IN INDUCED DRAFT BLOWER

- Produces power-induced draft of makeup air prior to burner ignition
- Provides more efficient control of heat through the flue collector
- No draft hood or barometric damper required

RATED AS CATEGORY 1 APPLIANCE

- Can be commonly vented with other Category 1 appliances, using standard metal type “B” vent

PERMAGLAS® ULTRA COAT GLASS LINING

- Exclusive process provides superior protection against corrosion
- CoreGard anode rods with stainless steel core provide additional corrosion protection

THREE WATER CONNECTION OPTIONS

- Hot and cold water connections can be made through top, front or rear of water heater
- The Eliminator self-cleaning device operates when cold water is connected through front

INTERMITTENT ELECTRONIC IGNITION

- Eliminates standing pilot
- Includes power ON/OFF switch
- Provides flame failure response in less than one second

FACTORY-INSTALLED TEMPERATURE & PRESSURE RELIEF VALVE

MAXIMUM HYDROSTATIC WORKING PRESSURE 160 PSI

80% THERMAL EFFICIENCY

CODES AND STANDARDS

- Design-certified by UL (Underwriters Laboratories), according to ANSZ21.10.3-CSA4.3 standards governing storage-type water heaters
- Meets ASHRAE/IESNA 90.1-1999
- Optional ASME construction available

WARRANTY

- Three-year limited warranty against tank leaks
- For complete warranty information, consult written warranty shipped with water heater, or contact A.O. Smith Water Products Company



Master-Fit[®] BOOSTER MODELS

CAPACITY, INPUT AND OUTPUT

MODEL NUMBER	BTU INPUT PER HOUR	Gallons or Litres	TANK SIZE	FIRST HOUR RATING	GPH or LPH	RECOVERY - GALLONS or LITRES PER HOUR AT DEGREE RISE				
						40°F	60°F	80°F	100°F	140°F
						22°C	33°C	44°C	56°C	78°C
BTR-151	150,000	U.S. Gallons	32	167	GPH	364	242	182	145	104
		Litres	121.1	632.1	LPH	1377.7	916	688.9	548.8	393.6
BTR-201	199,000	U.S. Gallons	32	216	GPH	485	322	241	194	139
		Litres	121.1	817.6	LPH	1835.7	1218.8	912.2	734.3	526.1

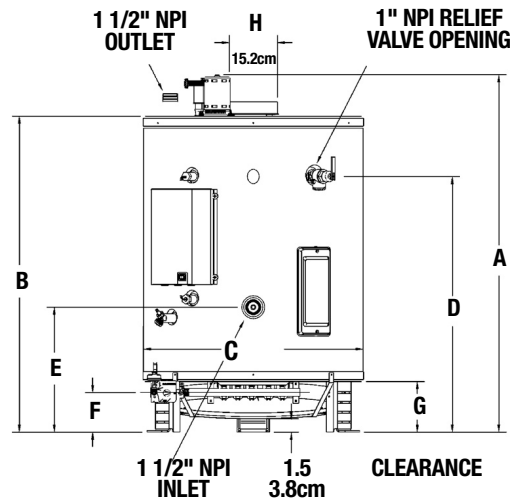

DIMENSIONS AND WEIGHT

MODEL NUMBER		DIMENSIONS								GAS CONN.	WATER CONN.	APPROX. SHIPPING WEIGHT (LBS.)
		A	B	C	D	E	F	G	H			
BTR-151 and BTR-201	inches	45	40	27-3/4	32-1/4	15-3/4	5	6-1/2	6	3/4	1-1/2	460
	cm	114.3	101.6	70.5	81.9	40	12.7	16.5	15.2	-	-	181.8

SUGGESTED SPECIFICATION

Gas booster water heater(s) shall be A.O. Smith Master-Fit, Model Number _____, with a 32-gallon storage capacity, an input rate of _____ BTU/HR, _____ gas, and a recovery rate of _____ gallons per hour at a _____ degree Fahrenheit temperature rise, and a maximum hydrostatic working pressure of 160 psi.

Unit(s) shall have a fan-assisted combustion system, providing a power-induced draft of makeup air prior to burner ignition. Unit(s) shall be equipped with intermittent electronic ignition with power on/off switch, which shall provide flame failure response in less than one second. The burner for the unit(s) shall be easily removable. Unit(s) shall be equipped with a factory-installed temperature and pressure relief valve, and a 2-3/4" x 3-3/4" tank inspection port.

The water heater tank shall be glasslined and protected against premature failure in the following ways:

1. Against electrolytic corrosion by multiple, factory-installed anode rods
2. Against failure due to overheating caused by the buildup of scale, film and other sediment by a self-cleaning device, positioned inside the tank so that it directs the flow of inlet water in such a way that microscopic particles of precipitated solids shall be kept in suspension and exhausted from the water heater on that or successive hot water draws.

Unit(s) shall meet or exceed ASHRAE/IESNA 90.1-1999, and be design certified by UL (Underwriters Laboratories), according to ANSZ21.10.3-CSA4.3 standards governing storage-type water heaters.